

X-Band Quad Beamforming TR Module

Frequency Range: 9-10 GHz

Features

- Output power options available: 1, 5 and 10W
- Four independent Tx/Rx channels
- Active phase and gain beam control
- 1 GHz bandwidth (9-10 GHz)
- Noise figure <3.5 dB
- Agile beam control via user accessible interface

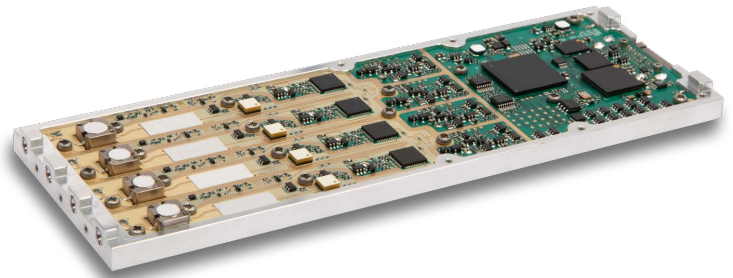

Benefits

- Range of power options to optimise the application
- Enables simple and rapid array development and integration
- Fully calibrated and temperature compensated units for simplified deployment
- Comprehensive Built-in-Test (BIT) and monitoring for reliable operation
- Power efficient design, single supply voltage to simplify system development
- GaN amplifiers for the latest in performance

Introduction

The Quad Transmit Receive Module (QTRM) is a versatile, feature rich module with channel independent active gain and phase control intended for AESA applications in the X band frequency range (9-10 GHz). Key application areas include RADAR and directional communications.

The QTRM has been developed to maximise ease of use and performance together with low simplified infield configurations and maintenance. The extensively calibrated modules reduce array-level test requirements during production and allows modules to be freely replaced within an array without affecting beam pattern when in service. Without this, system setup and maintenance would likely be significant.

Mechanically, the QTRM has been designed such that they can be mounted and linked via blind-mate RF SMPM connectors supporting a lattice geometry suitable for X-band antenna element spacing.

To support development and evaluation, the QTRM modules come with the option of having an evaluation assembly and reference antenna supporting one or more modules.

Beamforming

AESA arrays built from QTRM modules can be controlled on a pulse-by-pulse basis using direction cosines or scan patterns that can be pre-loaded with up to 512 steps. The phase and gain control blocks feature 6-bit resolution with a range of 360° and 31.5dB in 5.625° and 0.5dB steps respectively. QTRM modules can be scaled from a single quad transceiver to 1000s of channels. An onboard controller simplifies this process.

On module DSP Digital Control

The QTRM is easy to manage and control through a 5Mbps RS485 compatible serial interface to an on-module DSP processor. The RS485 control interface supports a multi-drop interface to one or more modules. Consequently, this interface can be used to address individual modules or broadcast to them all.

In addition to direction cosine setting, each QTRM supports over twenty modes include setting element position, Tx/Rx inhibit, diagnostics, power monitors, module specific data, calibration and setting of duty cycle.

Power Options to Application

The QTRM is available in three power output options of 1, 5 and 10W per channel. Each channel can support pulsed and intermittent CW applications. 5 and 10W/channel modules are dual-use export controlled.

Temperature Calibrated

All modules are temperature compensated and calibrated at factory for all frequency and phase variations – transmit and receive. Modules also include the capability of accepting user calibration offsets to compensate for array edge effects and side-lobe reduction windowing functions.

Each QTRM includes not only calibration units for itself, but also for the array. This means changing the TRM's position or using a replacement, can take on the calibration parameters for that position.

During test, each QTRM is calibrated such that all four channels optimally phase aligned.

Windowing

The QTRM has a table describing where it is in the array. Based on this, windowing functions can be applied based on its position in the array.

Diagnostics

Each module has fault-detection and protections built in, and incorporates extensive self-test and status monitoring capabilities providing real-time status enabling smart array management and logistics.

QTRM High Level Block Diagram

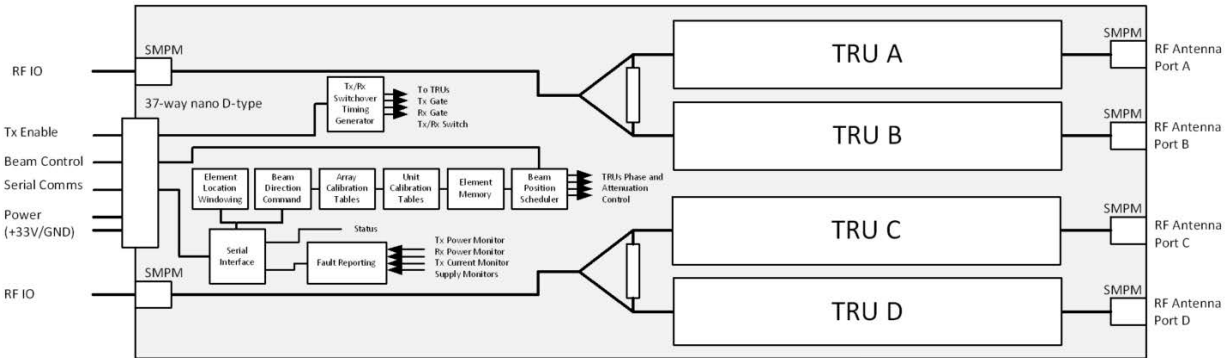

Transmit Receive Unit (TRU) Block Diagram

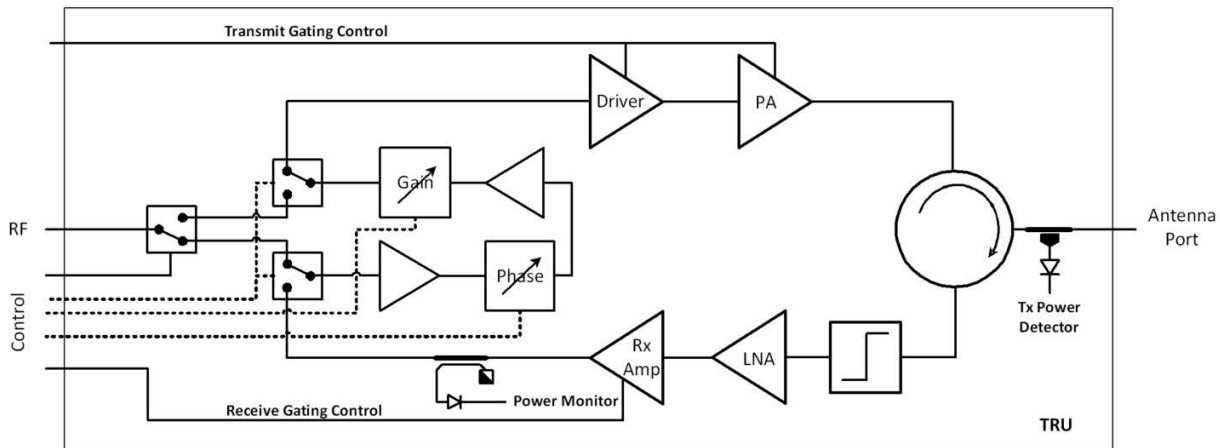

Evaluation Support

A complimentary accessory kit is available for the QTRM featuring a mounting kit, host computer interface cables and an option for a plug in antenna. The accessory kit provides an excellent way to come up to speed quickly and ideal for evaluating the performance of one or more (up to four units, each with its own accessory kit) QTRMs

A computer with a USB interface and a +33V power supply is required. For further information on the accessory kit, please see the datasheet for MAIA-100259.



Two QTRMs fitted to two accessory kits (antenna option not shown)

Specifications*

Parameter	Typical at 9.5GHz	Notes
General		
Frequency	9-10 GHz	
Tx/Rx Switching Speed	500 ns	After Gate Pulse
Input Return Loss	10 dB	
RF Pulse Width	2-100 μ s	80 μ s @ 30% max
Duty Cycle	10-30 %	
RF Pulse Rise and Fall Time	80 ns	
Transmit Parameters		
Tx P _{sat}	1, 5 or 10 W	Build Options
Tx Small Signal Gain	>30 dB	1W Option
	>40dB	5W and 10W Options
Tx Input Power Level	>5 dBm	5W and 10W Options
	>+10dBm	1W Option to allow for reduced gain) For optimum P _{sat} condition
Tx Power Variation	\pm 0.5 dB	Per 100 MHz in 9-10 GHz bandwidth P _{sat} condition
Receive Parameters		
Rx Gain	25 dB	For reference attenuation and phase states
RX Op1dB	2dBm	
Rx Gain Variation	\pm 1.5 dB	9-10 GHz bandwidth
Rx Noise Figure	3.5 dB	For reference attenuation and phase states
Receiver Protection	10 W _{pk}	Per channel
Beamforming		
Phase Shift Range	0-354.375°	6-bits, 64 states, 5.625° steps
RMS Phase Error	1 LSB	
Attenuator Range	0-31.5 dB	6-bits, 64 states, 0.5 dB steps
RMS Attenuator Error	1 LSB	
Switching Time	500 ns	From receipt of Beam Steer pulse
Stored Beam Steer Settings	512	Scheduler mode
Beam Steer Repetition Time	4 μ s	
Control Interface Rate	5 Mbps	

Specifications*

Digital Interface		
Host Interface (Beam Steering Computer Interface)	RS485	Asynch UART multi-drop
Transmit Enable	RS485	Asynch UART multi-drop
Beam Control	RS485	Asynch UART multi-drop
Power Supply		
DC Power Supply (Vs)	10W: 26-28V 1 & 5W: 22-28V	Linear power supply Contact factory for alternative voltages
Tx Power Consumption – 10W Option	50W (Ave): 26V Vs or 53.7W (Ave): 28V Vs @ 30% duty cycle	Power is Vs dependant 30% duty cycle max
Tx Power Consumption – 5W Option	27.7W (Ave): 22V Vs or 35.2W (Ave): 28V Vs @ 30% duty cycle	
Tx Power Consumption – 1W Option	17.2W (Ave): 22V Vs or 21.8W (Ave): 28V Vs @ 30% duty cycle	
Rx Power Consumption	10 W	(All Models – 4 channels powered)
Power Consumption – idle state	4 W	(All Models – RF unpowered)
Mechanical		
Size	178 x 59.5 x 14.5 mm	
Mass	285 g	
Digital Control and Power Supply	37-way Nano D-type female	
RF IOs	SMPM male	
RF Antenna Ports	SMPM male	
Environmental		
Operating Temperature	0 – 50°C	Contact factory for extended temperature
Storage Temperature	-40 - +85°C	
Export Control		
1 W option	Not controlled	
5 W option	3A001.b.12	Dual use
10 W option	3A001.b.12	Dual use
* Typical performance values are measured at 25°C		

Digital Interface and Power Pinout

Pin Number	Function	Compatibility
1, 2, 18-22, 34, 36, 37	Power Supply	+33 ±1 V
9-15	Ground	
24	+ Beam	RS485 multi-drop
25	- Beam	
26	- Transmit Enable	RS485 multi-drop
27	+ Transmit Enable	
28	- Beam Steering Computer Interface	RS485 multi-drop
29	+ Beam Steering Computer Interface	
3-8, 16, 17, 23, 30-31, 35	Reserved (do not use)	

QTRM Modes

In order to control the QTRM, the onboard controller supports a number of functions, both on a module by module basis or broadcast to all modules at the same time. This provide great flexibility, beamcontrol and diagnostic. See the QTRM mode table for an outline of the range of functions.

Set Mode	Set Array CAL	Get Element CAL	Get QTRM Address
Presets Element Attenuation	Set Element Position	Get Array CAL	Get Rx Power Monitors
Set Element Cosines	Set QTRM Address	Get Software Version	Get Tx Power Monitors
Set Element Tx Inhibit	Set Shutdown	Get Element Position	Get Drain Currents
Set Element Rx Inhibit	Set Restart	Get Element Info	Get RF Settings
Set Element Scheduler	Set Duty Cycle	Get Serial Number	
Set Element CAL	Get BIT	Get Lifetime Counter	

Performance Plots (5W)

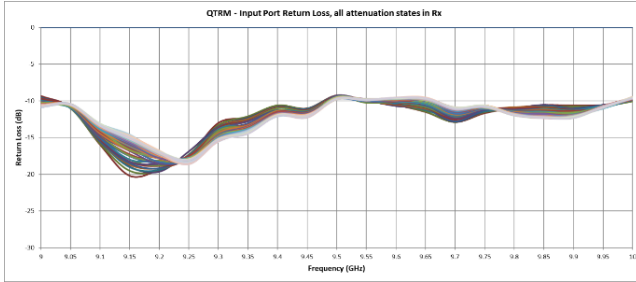

Typical input return loss

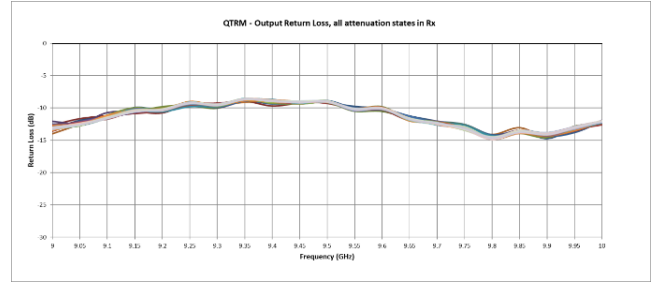

Typical output return loss

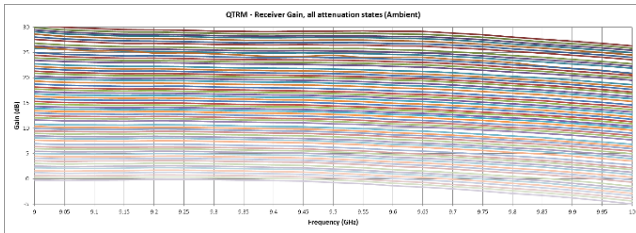

Typical Receiver gain

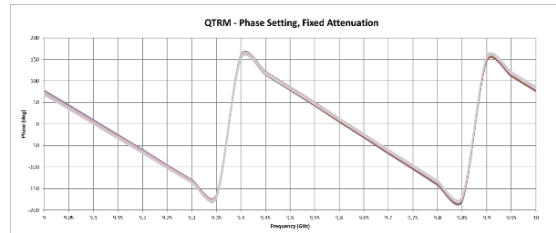

Typical phase adjustment

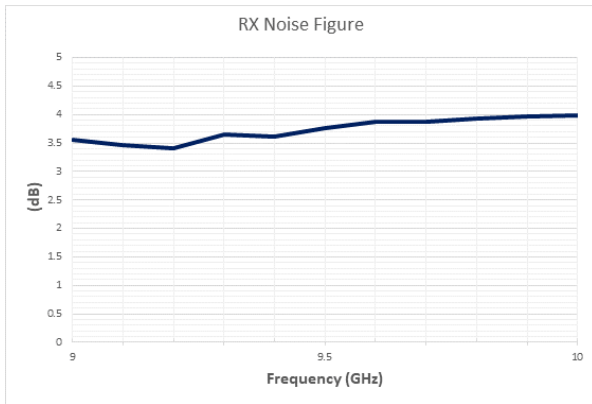

Typical noise figure

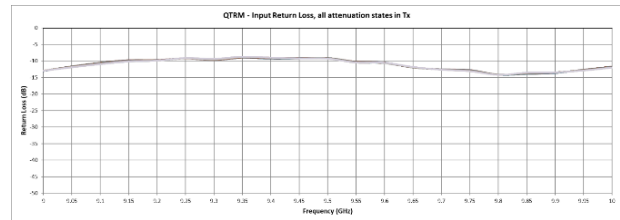

Typical Tx input return loss

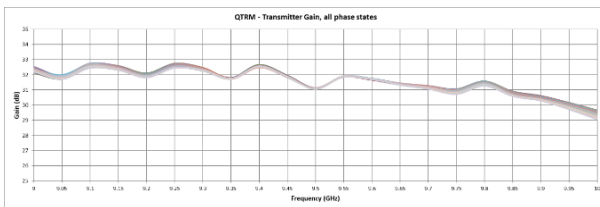

Typical large signal gain

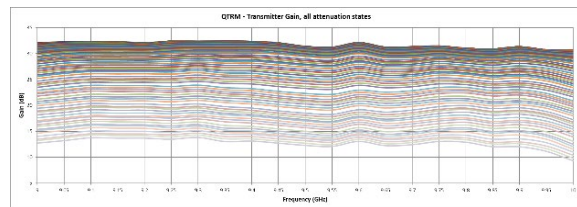

Typical Transmitter Gain

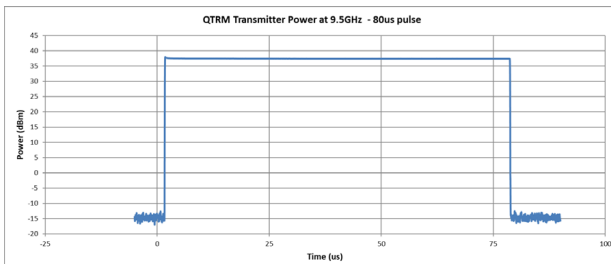

Typical transmitter pulse power

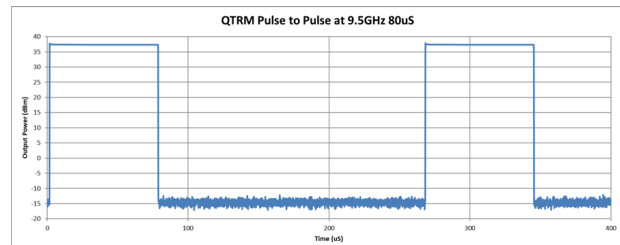

Typical pulse to pulse power

Performance Plots 1W Variant

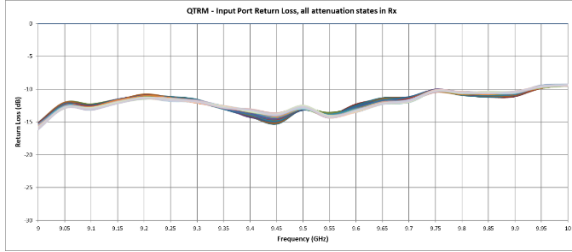

Typical input return loss

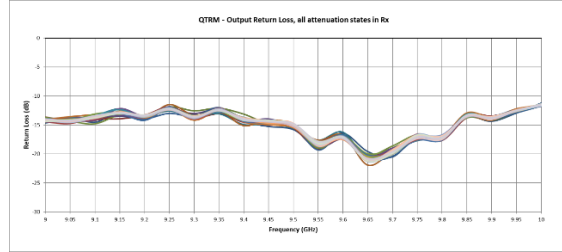

Typical output return loss

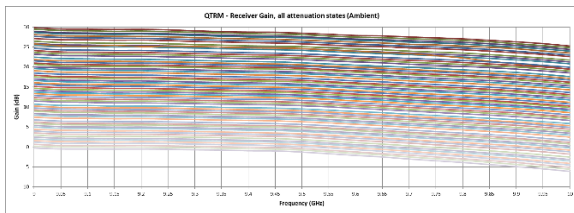

Typical receiver gain – all states

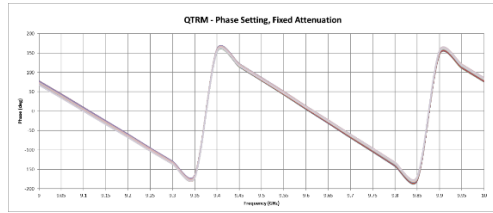

Typical phase adjustment

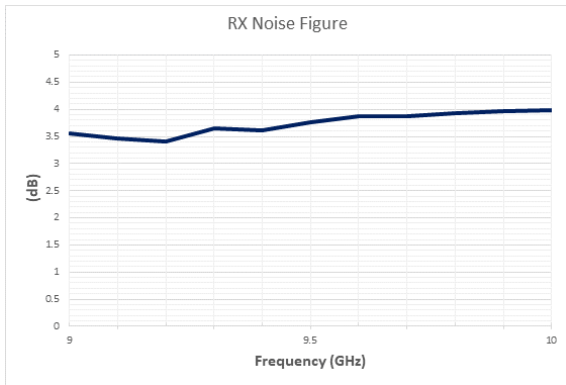

Typical noise figure

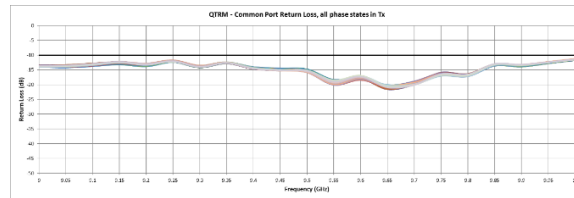

Typical input return loss

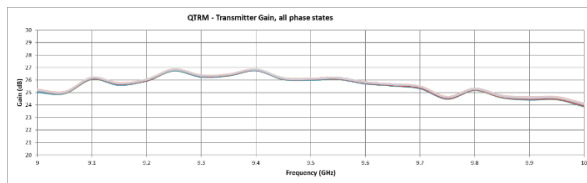

Typical large signal gain

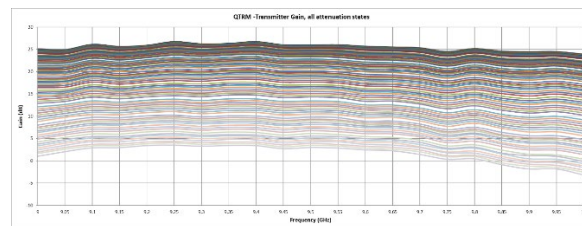

Typical transmitter gain – all states

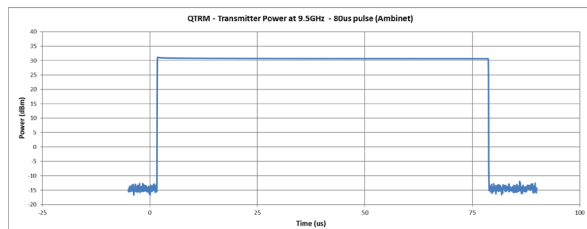

Typical transmit power

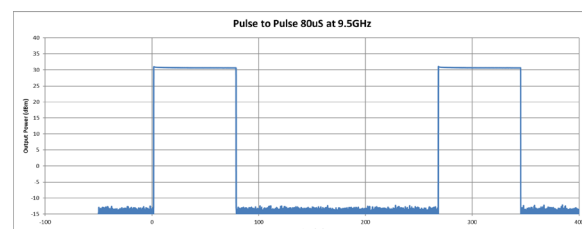

Typical transmit power – pulse to pulse

Ordering Information

1 W X-band QTRM	MAIA-100262
5 W X-band QTRM	MAIA-100240
10 W X-band QTRM	MAIA-100258
QTRM Accessory/Evaluation Kit	MAIA-100259
4-element Vivaldi option for accessory/evaluation kit	MAAN-100261

Mechanical Outline

