

# Attenuator, Type N (Reduced Width)

Model XN100WR

## Features

- Compact physical design
- Ruggedized construction
- Unidirectional
- Optimized for test applications

## Technical Specifications

Parameter		Value	
Frequency Range		DC to 6 GHz	
Standard Freq. Values		2.5 & 6 GHz	
Standard dB Values		3, 6, 10, 20, 30 & 40dB	
Attenuation Accuracy (dB)			
dB Value	DC-1.5 GHz	1.5-2.5 GHz	2.5-6 GHz
3 & 6	±0.50dB	±0.50dB	±0.75dB
10	±0.75dB	±0.75dB	±2.50dB
20 & 30	±0.75dB	±0.75dB	±1.50dB
40	±1.50dB	±1.50dB	±2.50dB
VSWR (Max)	1.25:1	1.35:1	1.45:1
Input Power	100 Watts Avg. @+25°C <i>Derated Linearly to 20 Watts @ +125°C</i>		
Reverse Power	20 Watts Max.		
Peak Power	1 kW Max. <i>(5µSec Pulse, .05% Duty Cycle)</i>		
Impedance	50 Ohms		
Operating Temp. Range	-55°C to +125°C		

Frequency Range: DC to 6.0 GHz  
Power: 100 Watts



## Mechanical

Feature	Material
Type N Connectors <i>Mates with MIL-STD-348</i>	Passivated Stainless Steel
Conductors	Gold Plated Beryllium Copper
Housing	Anodized Aluminum

Units must be mounted in such a way as to allow for free air flow around fins as to assure performance.

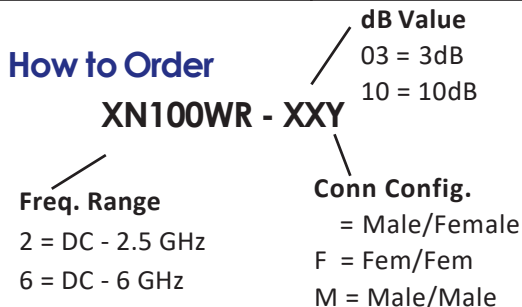

## Order Examples

Model Number: 6N100WR-10

DC-6 GHz, 10dB, Type N Male/Fem

Model Number: 2N100WR-03F

DC-2.5 GHz, 3dB, Type N Fem/Fem

Design Specifications are subject to change without notice.

REV A

# Attenuator, Type N (Reduced Width)

Model XN100WR

## Physical Dimensions

Model Number: 2N100WR-03 shown

**Frequency Range: DC to 6.0 GHz**  
**Power: 100 Watts**

Units are unidirectional, therefore input connector must be specified and will be indicated on unit.

Dimensions in Brackets are in millimeters and are for reference only.

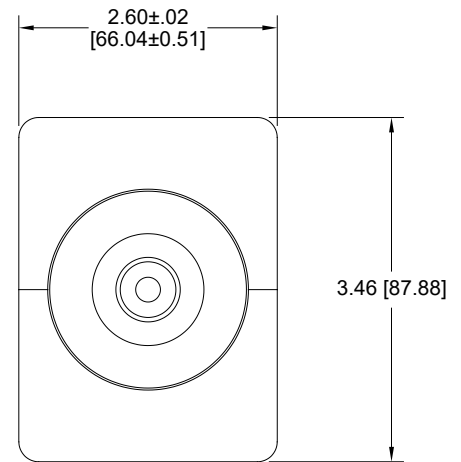
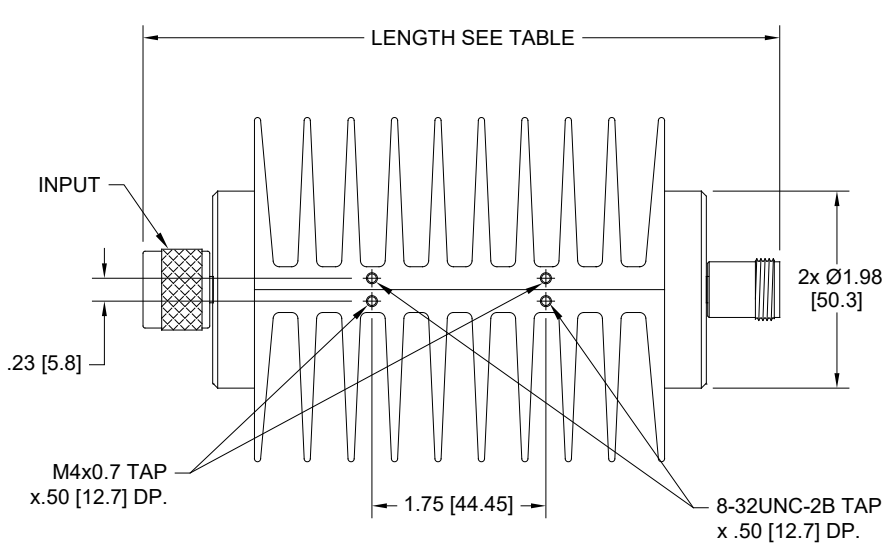

## Recommended Mounting

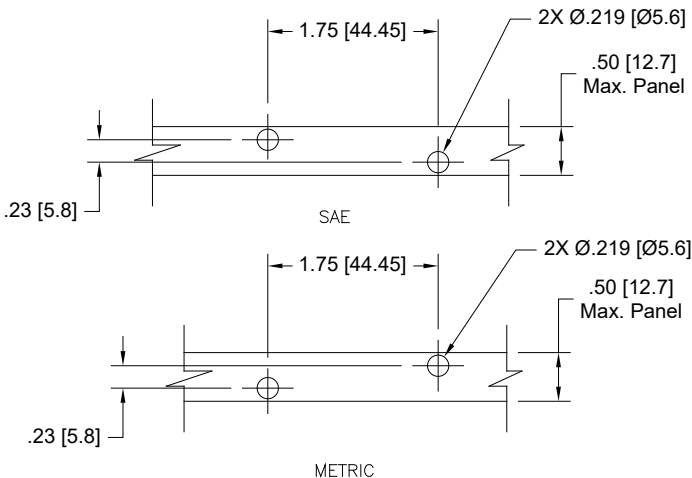

Model number	Conn. Config.	Length
XN100WR-XX	Male/Fem	6.36 ±.05 [161.5 ±1.3]
XN100WR-XXF	Fem/Fem	6.45 ±.05 [163.8 ±1.3]
XN100WR-XXM	Male/Male	6.28 ±.05 [159.5 ±1.3]

Design Specifications are subject to change without notice.

REV A