

SMPS Capacitor Assemblies

Designed to provide superior performance in high frequency switching applications.

Mil Qualified & DSCC Certified

APITech's line of MIL-PRF-49470 qualified and DSCC 87106 certified High-speed Switch Mode Power Supply (SMPS) capacitors are ideal for high energy density products found in both defense and commercial markets.

Dielectric Characteristics

APITech offers SMPS capacitors in two basic dielectric classes, with individual designs tailored to meet specific performance characteristics.

Dielectric Type	Stability Class	Description
BP (NPO/COG)	Ultra Stable Class I	Effects on electrical properties are minimal with variations in operating temperature, voltage, frequency, or time. Used in applications which require stable performance.
BQ, BR and BX	Ultra Stable Class II	Class II dielectrics will exhibit a predictable shift in performance characteristics when exposed to variations, frequency, or time. Selected for applications where blocking, coupling, by-passing, and frequency discriminating elements are used. Offers higher capacitance than Class 1 (COG).

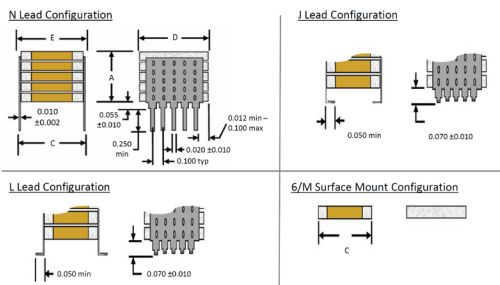

Features

- Multilayer ceramic capacitors
- Ideal for DC-DC power supply applications
- Capacitor assemblies with low ESR/ESL
- Capacitance values 0.01µF to 47µF
- Leaded parts safeguard against thermal and mechanical stresses
- Designs available for both defense and commercial markets
- Mil-PRF-49470 qualified, DSCC 87106, custom, and standard products available

Style & Size	Dimensions						
	A Max	B Max	C ±0.025"	D ±0.025"	E Max	Leads/Side	
SMP-3	(in)	0.650	0.715	0.450	1.050	0.500	10
	(mm)	16.50	18.16	11.42	26.65	12.69	
SMP-4	(in)	0.650	0.715	0.400	0.400	0.440	4
	(mm)	16.50	18.16	10.15	10.15	11.17	
SMP-5	(in)	0.650	0.715	.250	.250	0.300	3
	(mm)	16.50	18.16	6.35	6.35	7.62	

SMPS Part Numbering System

Example: I8150173X7R471Mz

The part number shown represents a size 3 SMPS capacitor. The ceramic type will be BX, capacitance value is 120,000 pF, with a tolerance of ±10%. The voltage rating is 500 VDC, termination will be "N" style leads and the parts will receive marking/bulk packaging.

SMP3	X	124	K	E	N	M	B	00
Case Size SMP3 SMP4 SMP5	EIA Cap Code Example: 120,000 pF	EIA Cap Tolerance J: ±5% K: ±10% M: ±20%	Voltage Rating Z: 25 VDC A: 50 VDC B: 100 VDC C: 200 VDC E: 500 VDC	Termination J: Leads in L: Leads out K: Leads staight	Marking M: Marked U: Unmarked	Packaging T: Tape & Reel F: Foam Carrier/boxed W: Waffle B: Bulk	Special Requirements GA: 87106 Group A HR: Hi-Rel*	
	Ceramic Code P: BP Q: BQ R: BR X: BX							

* Designation on page 2.

SMPS Capacitor Assemblies

Military/Hi-Rel & Commercial/Industrial Grade.

APITech offers high reliability/military grade and commercial/industrial grade capacitors designed to provide superior performance in high frequency switch mode power applications.

These capacitors are ideal for bulk capacitance and pulsing applications and are available in a range of different footprints and mounting configurations. The high reliability/military grade is based on the design principals and test requirements defined by MIL-PRF-49470.

- Leaded options safeguard against thermal and mechanical stresses is larger package sizes
- Capacitance values 0.01 μF to 150 μF
- Stable class II, BX, BR, BQ, and X7R dielectric materials offer reliable operation and predictable performance characteristics related to temperature, frequency, and voltage

APITech's high-speed Switch Mode Power Supply capacitors have the following characteristics when compared to other capacitor technologies:

- Multilayer ceramic capacitors
- Ideal for DC-DC power supply applications
- Capacitor assemblies with low ESR/ESL

Electrical Characteristics

VTC	WVDC	Maximum Capacitance Value									
		2225	2425	3530	3640	3940	4540	5550	6560	7565	44105
X7R	50	156	156	276	396	476	566	826	127	157	157
X7R	100	685	685	126	186	206	256	396	566	686	586
X7R	200	475	475	685	825	106	126	156	256	336	276
X7R	500	155	155	275	395	395	475	685	825	126	126
BX	50	475	565	106	126	156	185	276	396	576	476
BX	100	215	335	475	575	825	825	125	186	226	276
BR	200	125	155	255	395	395	475	685	106	126	126
BQ	500	564	684	125	155	185	185	275	475	565	565

Dimensions

Refer to drawings on previous page

Dimensions in (mm)	Case Size									
	2225	2425	3530	3640	3940	4540	5550	6560	7565	44A5
C	0.235 (5.97)	0.250 (6.35)	0.360 (9.14)	0.370 (9.40)	0.400 (10.16)	0.460 (11.68)	0.560 (14.22)	0.660 (16.76)	0.760 (19.30)	0.450 (11.42)
$\pm 0.025(0.635)$										
D	0.244-0.275 (5.69-6.99)	0.244-0.275 (5.69-6.99)	0.275-0.325 (6.99-8.26)	0.350-0.425 (8.89-10.80)	0.350-0.425 (8.89-10.80)	0.350-0.425 (8.89-10.80)	0.450-0.525 (11.43-13.34)	0.550-0.625 (13.97-15.88)	0.600-0.675 (15.24-17.15)	0.950-1.075 (24.13-27.31)
Min - Max										
E Max	0.300 (7.62)	0.300 (7.62)	0.420 (4.67)	0.430 (10.92)	0.430 (11.17)	0.53 (13.46)	0.630 (16.00)	0.730 (18.54)	0.830 (21.08)	0.500 (12.70)
A Max	0.650 (16.51)	0.650 (16.51)	0.650 (16.51)	0.650 (16.51)	0.650 (16.51)	0.650 (16.51)	0.650 (16.51)	0.650 (16.51)	0.650 (16.51)	0.650 (16.51)
# Leads/Slide	3	3	4	4	4	4	5	6	6	10

Note: C dimension for non-leaded, chip capacitors equals dimension specified less thickness of the leads or 0.020" total.

SMPS Part Numbering System

Example: 2225X824KAJMBHR

The part number shown represents a 2225 size SMPS capacitor. The ceramic type is X7R/BX, capacitance value is 0.82 μF , with a tolerance of $\pm 10\%$. The voltage rating is 50 VDC, termination is "J" style leads, Group A testing is M49470 Group A, Subgroups 1 & 2 and the parts will receive marking/ bulk packaging.

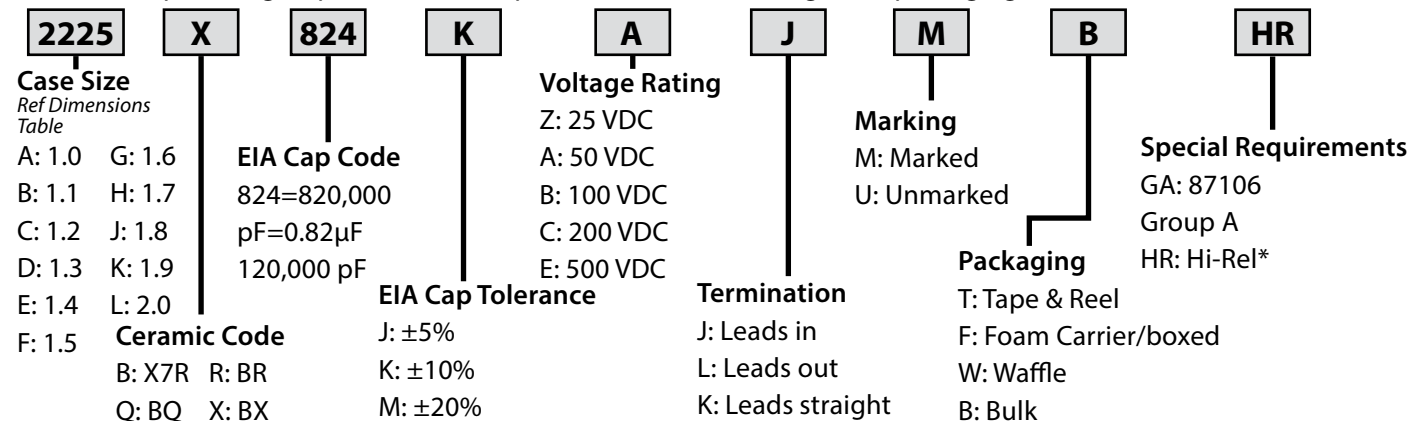

* 00 designation reflects sample visual/mechanical inspection, plus 100% capacitance, DF, DWV, & IR testing @+25°C HR designation reflects Group A, Subgroups 1 & 2 inspection per MIL-PRF-49470

SMPS Specifications

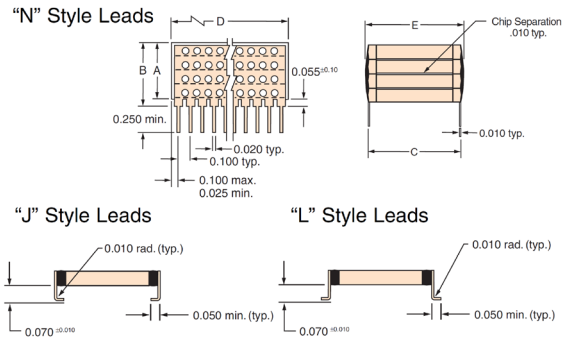

Cap Value (µF)	BP				BX				BR				BQ			
	Working Volts DC				Working Volts DC				Working Volts DC				Working Volts DC			
	500	200	100	50	500	200	100	50	500	200	100	50	500	200	100	50
0.01	█															
0.012	█															
0.015	█															
0.018	█	█														
0.022	█	█														
0.027	█	█														
0.033	█	█														
0.039	█	█														
0.047	█	█														
0.056	█	█														
0.068	█	█														
0.082	█	█														
0.10	█	█														
0.12	█	█														
0.15	█	█														
0.18	█	█														
0.22	█	█														
0.27	█	█														
0.33	█	█														
0.39	█	█														
0.47	█	█														
0.56		█														
0.68		█														
0.82		█														
1			█													
1.2			█													
1.5			█													
1.8				█												
2.2				█												
2.7				█												
3.3																
3.9																
4.7																
5.6																
6.8																
8.2																
10																
12																
15																
18																
22																
27																
33																
39																
47																

KEY: █ SMP-3 █ SMP-4 █ SMP-5

SMPS Capacitor Electrical Testing

**Absolute Maximum Output Capacitance
Assuming no ESL and no ESR**

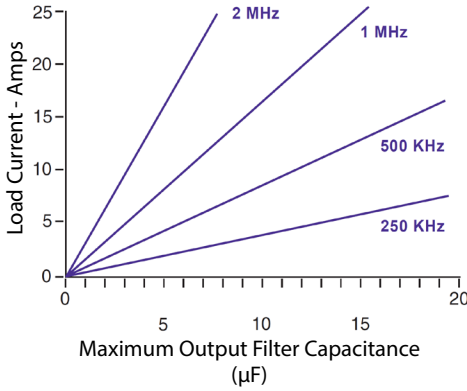

ESR vs. Frequency

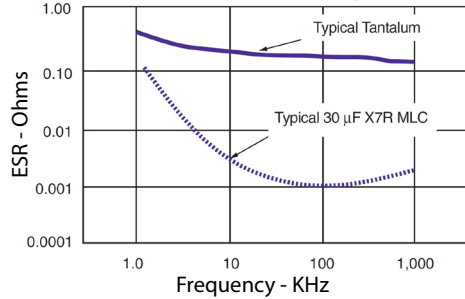

**Absolute Maximum Capacitance ESL
Assuming no ESR - Capacitive Induced Ripple**

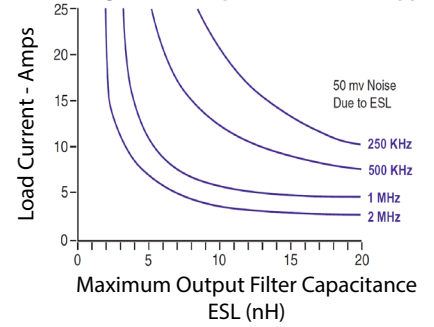

Impedance vs. Frequency

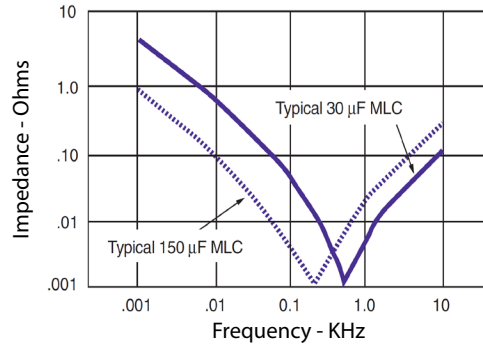

**Absolute Maximum Capacitance ESR
Assuming no ESL - Capacitive Induced Ripple**

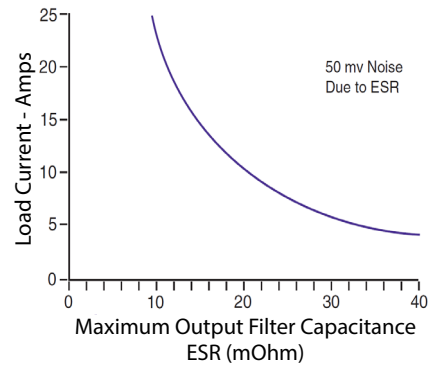

Test Group	Test Order	Test	Test Method	Post Test Requirements	Sampling Procedure
Group A	1	Visual and Mechanical			13 samples 0 failures
	2	Materials, Designs, Construction and Workmanship			
	3	Physical Dimensions and Marking			
	4	Capacitance and Dissipation Factor			
	5	Dielectric Withstanding Voltage	MIL-STD-202 Method 301 2.5x DCWV except 500V 1.5x		100%
	6	Insulation Resistance	MIL-STD-202 Method 302 @ DCWV, 25 C	>100,000 megohms or 1,000 megohm-µF, whichever is less	
Group B Sub Grp I	1	Voltage and Temperature Limits			12 samples 1 failures
	2	Resistance to Solvents	MIL-STD-202 Method 215		
	3	Immersion	MIL-STD-202 Method 104 test condition B	No mechanical damage. Dielectric strength, capacitance, df and 25 C IR to original limits	
	4	Terminal Strength	MIL-STD-202 Method 211 test condition A. Case codes 1-4, 6-5 lbs, case code 5-4 lbs	No evidence of loosening or rupturing of terminals	
Group B Sub Grp II	1	Resistance to Soldering Heat	MIL-STD-202 Methos 210 N lead style test condition B, J and L styles test condition I	No mechanical damage. Dielectric strength, capacitance, df and 25 C IR to original limits	12 samples 1 failures
	2	Moisture Resistance	MIL-STD-202 Method 106 20 cycles	No mechanical damage. Dielectric strength, capacitance, df and 25 C IR to original limits	
Group B Sub Grp III	1	Life	MIL-STD-202 Method 108, 1000 hrs, 2x DCWV except 1.2x500 DCWV	No mechanical damage. Dielectric strength, capacitance, df and 125 C IR to original limits	12 samples 1 failures
Optional		Solderability Group A			
		Thermal Shock and Voltage Conditioning			

Processing & Soldering Notes

General Soldering Recommendations for Leadless Ceramic Capacitors

Soldering Ceramic Capacitors with High Temperature Process

SN10 Solder

Ramp Rate, Heating and Cooling: Approx. 30°C/min.

Peak Temperature: Approx. 320°C

Dwell at Peak: <30 Seconds

Soldering Ceramic Capacitors with Medium Temperature Process

SN96 Solder

Ramp Rate, Heating and Cooling: Approx. 30°C/min.

Peak Temperature: Approx. 250°C

Dwell at Peak: <30 Seconds

Soldering Ceramic Capacitors with Low Temperature wProcess

SN62 Solder

Ramp Rate, Heating and Cooling: Approx. 30°C/min.

Peak Temperature: Approx. 220°C

Dwell at Peak: <30 Seconds

Notes

Care must be taken to minimize the time silver terminations are exposed to molten solder to avoid leaching (amalgamation of the silver into molten solder). APITech recommends the use of a silver (Ag) bearing solder when terminating directly to ceramic ceramic capacitors to reduce the potential for leaching. Gradual heating and cooling of the components are essential to prevent thermal stresses to the ceramic.

Application Note: Soldering Recommendations for Switch Mode Power Supply Capacitors

- SMPS capacitors are highly durable structures designed to provide long service per lifetime, however they require attention to basic considerations during assembly. Like all ceramic components, SMPS capacitors are subject to thermal stresses. For this reason, preheating of the capacitor assemblies is recommended. Preheat components using hot plate to 120 to 150°C, or within 50 to 60°C of the soldering temperature being applied. Avoid over-exposure to high temperatures during assembly and allow for gradual, post-assembly cooling.
- For hand iron soldering, recommended soldering iron tip temperature is 330 to 350°C. Contact the pad adjacent to the pre-tinned lead should be made from below the PCB (opposite of the component side), and the dwell time on the solder joint should be less than five seconds. An aluminum heat sink plate may be placed adjacent to the SMPS lead frame to protect the ceramic body during assembly. Avoid direct contact between soldering iron and ceramic during assembly process. Soldering time is dependant upon heat sinking provided by the chassis and boardmaterial, so a longer preheat cycle may be required.
- Standard solders (Sn60, Sn63, Sn60/38/2) may be used. Please consult the factory for use with RoHS compliant solders.
- Use a controlled temperature profile ramp not exceeding 4°C per second as measured by an attached low mass thermocouple.
- Soldering time and temperatures can vary with component size, board material and layout. Please consult the factory for assistance.