

DC Blocks SMA

10 MHz – 4 GHz Inner Only

MODEL: 8529A

Technical Specifications

Parameter	Value
<i>Electrical</i>	
Frequency Range	10 MHz – 4 GHz
VSWR	1.60:1 max.
Impedance	50 Ohms
Insertion Loss	1.5 dB max.
Working Voltage	900 Volts
Operation Temp. Range	-65°C to +125°C

Parameter	Value
<i>Mechanical</i>	
Connectors Mates with MIL-STD-348	Passivated Stainless Steel
Conductors	Gold Plated Beryllium Copper

Model Number 8529A

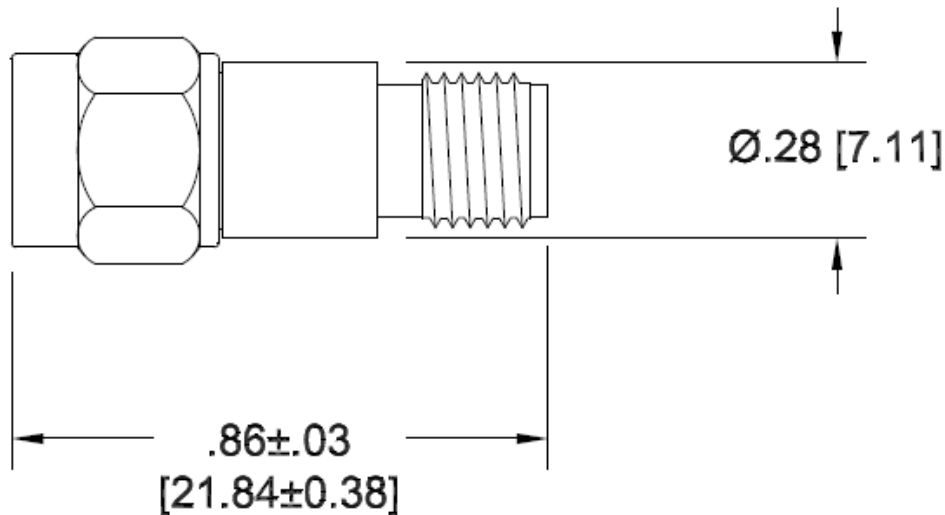

***Dimensions in brackets are expressed in millimeters and are for reference only.

sales@am.spectrumcontrol.com

Approved for Release: November 2024/Brown

Spectrum Control reserves the right to make changes to datasheets at any time without notice.