

Models 7004A & 7005A
 SMA; Type N; 3.5mm; SMK; 2.4mm

DC to 40.0 GHz

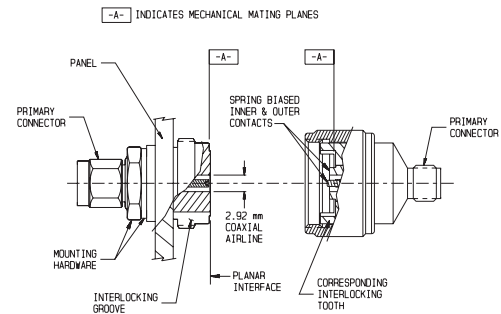

Features

The use of **PLANAR CROWN®** connectors on instruments, cables, components/accessories offers the manufacturer and user the following benefits.

Reduced Downtime - Damaged connectors can be replaced in seconds without any tools. Repair cost is minimized to that of a single connector. Recalibration, in most applications, is virtually eliminated due to closely matched phase, mechanical dimensions and insertion loss of the replaceable **PLANAR CROWN®** assemblies.

Versatility - Ability to select different connector types adds versatility to instruments, cables, systems and accessories. It offers the end user multiple connector options. Connector type and sex can be readily interchanged as dictated by the system/DUT, eliminating the need for adapters.

Superior Electrical Performance than would be obtained by additional adapters.

Simplified Network and Power Measurements on non-insertable devices.

Non-rotational Interface - Since the **PLANAR INTERFACE** has interlocking teeth, it eliminates unthreading of the connection when the Crown is subjected to a rotational torque. This feature is especially useful on coaxial cables where one end unthreads so easily when the cable is subjected to twisting or flexing.

Torque Independent Connection - A torque wrench is not required when mating the Crown to the bulkhead. A reasonable hand tightening of the coupling nut results in an excellent RF connection. This is achieved by having spring biased inner and outer contacts in the Crown connectors. Spring biasing ensures an intimate electrical contact at the **PLANAR INTERFACE**. A pilot diameter on the bulkhead guarantees excellent concentricity.

Axial Isolation of the Center Contact - Any excessive axial force on the Crown center contact is absorbed by the spring biasing at the Planar interface end.

Standardized Mounting Holes - All instrument panels can be fabricated with a standard 3/8" Dia. D-hole independent of the front panel connector type/sex. This eliminates changes in sheet metal design when different connector options are requested.

Description

The **PLANAR CROWN® UNIVERSAL CONNECTOR SYSTEM** is comprised of two connector halves/subassemblies which have a common mating interface referred to as the **PLANAR INTERFACE**. The first connector half is called the **PLANAR BULKHEAD** which readily mounts into instrument front panels, components and cables. One end of this bulkhead has a 2.92mm (SMK) male/female primary connector. The other end has a combination of grooves, external threads and a coaxial **PLANAR INTERFACE** with a 2.92mm (SMK) airline geometry. The bulkhead operates mode free beyond 40 GHz. The second connector half, called the **PLANAR CROWN®**, has a similar 2.92mm **PLANAR INTERFACE** on one end, with spring biased inner and outer contacts. It has corresponding projections which interlock with slots on the bulkhead and a coupling nut which secures the two connector halves, resulting in a non-rotational, torque independent electrical connection. The spring biased inner and outer contacts eliminate the need for specifying proof torque and no tools are required to mate or unmate or break the connection. The primary end of the **PLANAR CROWN®** is offered in various primary coaxial connector configurations such as SMA, Type N, 3.5mm, 2.92mm (SMK), and 2.4mm, thus providing an extremely versatile connector system wherein a connector can be replaced in seconds.

Planar Blind-Mate® Connectors Specifications



Specifications

PLANAR CROWN CONNECTORS

PLANAR BULKHEAD CONNECTORS

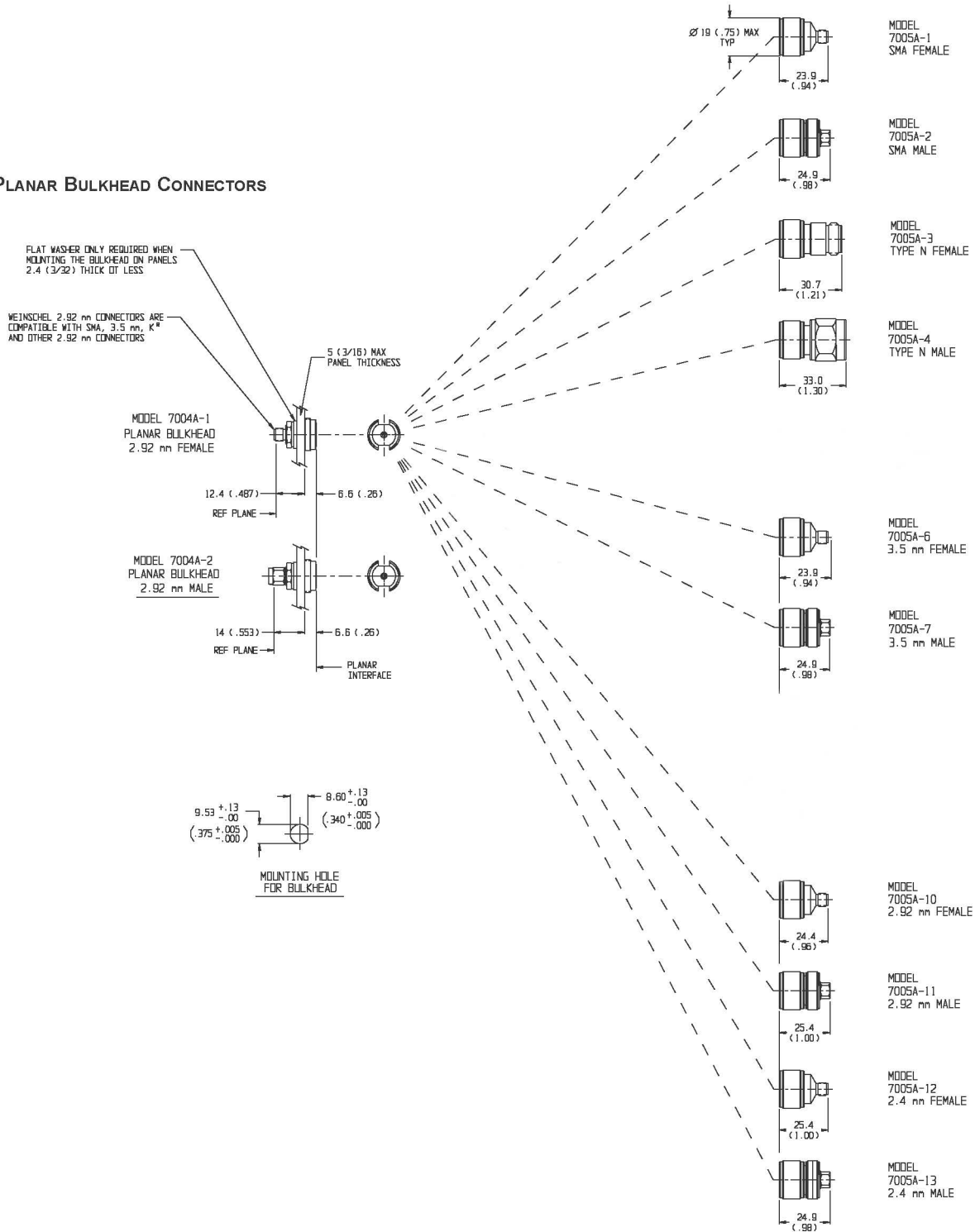



U.S. Patent No. 4,836,801
(Other U.S. and foreign patents pending)

NOTES: 1. All dimensions are given in mm (inches) and are nominal, unless otherwise specified.
2. K[®] is a registered trademark of the Wiltron 2.92mm connector











Planar Blind-Mate® Connectors

DC to 40 GHz

PLANAR BULKHEAD Connectors . . . DC to 40.0 GHz

Model Number/ Primary Conn.	Frequency Range (GHz)	SWR* (maximum)	Insertion Loss * (dB maximum)	Electrical Length	
7004A-1 2.92mm Female	DC - 40	----	----	19.9 ± 0.25mm	
7004A-2 2.92mm Male	DC - 40	----	----	21.6 ± 0.25mm	

PLANAR CROWN Connectors . . . DC to 40.0 GHz

Model Number/ Primary Conn.	Frequency Range (GHz)	SWR* (maximum)	Insertion Loss * (dB maximum)	Electrical Length	
7005A-1 SMA Female	DC - 26.5	1.20 (DC -18 GHz) 1.25 (18 - 26.5 GHz)	0.25 (DC -18 GHz) 0.35 (18 - 26.5 GHz)	18.6 ± 0.25mm	
7005A-2 SMA Male	DC - 26.5	1.20 (DC -18 GHz) 1.25 (18 - 26.5 GHz)	0.25 (DC -18 GHz) 0.35 (18 - 26.5 GHz)	18.6 ± 0.25mm	
7005A-3 Type N Female	DC - 18	1.20	0.25	18.6 ± 0.25mm	
7005A-4 Type N Male	DC - 18	1.20	0.25	28.6 ± 0.25mm	
7005A-6 3.5mm Female	DC - 33	1.20 (DC -18 GHz) 1.25 (18 - 26.5 GHz) 1.30 (26.5 - 33 GHz)	0.25 (DC -18 GHz) 0.35 (18 - 34 GHz)	18.0 ± 0.20mm	
7005A-7 3.5mm Male	DC - 33	1.20 (DC -18 GHz) 1.25 (18 - 26.5 GHz) 1.30 (26.5 - 33 GHz)	0.25 (DC -18 GHz) 0.35 (18 - 34 GHz)	18.0 ± 0.20mm	
7005A-10 2.92mm Female	DC - 40	1.20 (DC -18 GHz) 1.25 (18 - 26.5 GHz) 1.35 (26.5 - 40 GHz)	0.25 (DC -18 GHz) 0.35 (18 - 26.5 GHz) 0.45 (26.5 - 40 GHz)	18.0 ± 0.15mm	
7005A-11 2.92mm Male	DC - 40	1.20 (DC -18 GHz) 1.25 (18 - 26.5 GHz) 1.35 (26.5 - 40 GHz)	0.25 (DC -18 GHz) 0.35 (18 - 26.5 GHz) 0.45 (26.5 - 40 GHz)	18.0 ± 0.15mm	
7005A-12 2.4mm Female	DC - 40	1.20 (DC -18 GHz) 1.25 (18 - 26.5 GHz) 1.35 (26.5 - 40 GHz)	0.25 (DC -18 GHz) 0.35 (18 - 26.5 GHz) 0.45 (26.5 - 40 GHz)	18.0 ± 0.15mm	
7005A-13 2.4mm Male	DC - 40	1.20 (DC -18 GHz) 1.25 (18 - 26.5 GHz) 1.35 (26.5-40 GHz)	0.25 (DC -18 GHz) 0.35 (18 - 26.5 GHz) 0.45 (26.5-40 GHz)	18.0 ± 0.15mm	

Notes: 1. Specifications based on mated pair of 7004A-X and 7005A-XX. Refer to mating PLANAR CROWN for SWR and Insertion loss specifications.
 2. 2.92mm connectors are compatible with SMA, 3.5mm, SMK and other 2.92mm connectors.

Planar Blind-Mate® Connectors Specifications

General Specifications

PLANAR INTERFACE REPEATABILITY¹:

Reflection Coefficient (Magnitude):

60 dB (DC - 18 GHz)
50 dB (18 - 26.5 GHz)
45 dB (26.5 - 40 GHz)

Transmission (Magnitude)²:

40 dB (DC - 18 GHz)
35 dB (18 - 26.5 GHz)
30 dB (26.5 - 40 GHz)

Transmission (phase)²: 0.5°

1. The Repeatability specifications apply to ten consecutive disconnections and reconnections of the PLANAR INTERFACE.
2. Transmission repeatability includes the repeatability of the VNA test cable.

OPERATING TEMPERATURE: 0°C to 85°C

CONSTRUCTION: Passivated stainless steel bodies and coupling nuts. Gold plated beryllium copper contacts.

INTERFACE DIMENSIONS & ADDITIONAL FEATURES OF PRIMARY CONNECTORS:

SMA (Models 7005A-1 and -2):

Contact Pin Recession: 0 to 0.1mm (0 to 0.004 in)

Front Insulator Recession: 0.23 to 0.33mm (0.009 to 0.013 in)

Weinschel high frequency **SMA** connector operates mode free beyond 26.5 GHz and is a superior SMA connector. It incorporates a wider shoulder on the male and female mating planes (0.020" typical compared to 0.007" on standard SMA connectors) and has a 3 slot female contact instead of the conventional four slot design. Both these features result in a **more rugged** connector with longer life and improved repeatability. Unlike many commercial Teflon loaded SMA connectors, these connectors will not cause premature damage when mated with 3.5mm, 2.92mm and SMK connectors.

Type N (Models 7005A-3 and -4):

Contact Pin Protrusion (N female): 5.18 to 5.26mm (0.204 to 0.207 in)

Contact Pin Recession (N Male): 5.28 to 5.36mm (0.208 to 0.211 in)

The male and female Type N connectors are Precision Test connectors per MIL-STD-348. They are usable to 22 GHz.

3.5mm (Models 7005A-6 and -7):

Contact Pin Recession: 0 to 0.08mm (0 to 0.003 in)

2.92mm (Models 7005A-10 and -11):

Contact Pin Recession: 0 to 0.08mm (0 to 0.003 in)

In addition to the many advantages of 2.92mm airline connectors the Weinschel version incorporates a three slot female contact design resulting in a more ruggedized contact than the conventional four slot design on most 2.92mm connectors.

2.4mm (Models 7005A-12 and 7005A-13):

Contact Pin Recession: 0 to 0.08mm (0 to 0.003 in)

Applications

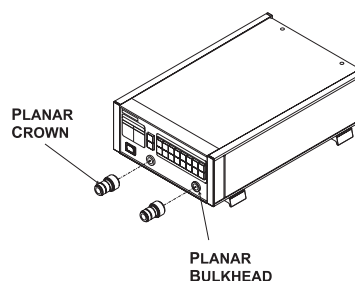

Test Instruments - Synthesizers; network/spectrum analyzers, power meters and many more.

Accessories - Detectors, SWR bridges/auto testers; power sensors, etc.

Microwave Cables - Cables constructed with the **PLANAR BULKHEAD** connector interface at one end offer the user a wide choice of primary coaxial connectors offered on the **PLANAR CROWN** models. For an instrument such as a VNA, this eliminates the need for having different sets of test cables for different connector configurations. Cables with a built in **PLANAR CROWN** on the opposite end mate directly with **PLANAR BULKHEADS** on instruments, providing an excellent non-rotational electrical connection.

Special Configurations - The **PLANAR BULKHEAD** design can be provided with a built in attenuator or DC block. This is a useful feature when instrument front ends require a masking attenuator or need to be protected against DC voltages. Although the basic mechanical design of the **PLANAR BULKHEAD** was intended for panel mounting, it can be modified to mount directly into other accessories. The primary connector of the bulkhead can also be modified to launch directly on microstrip or suspended stripline substrates.