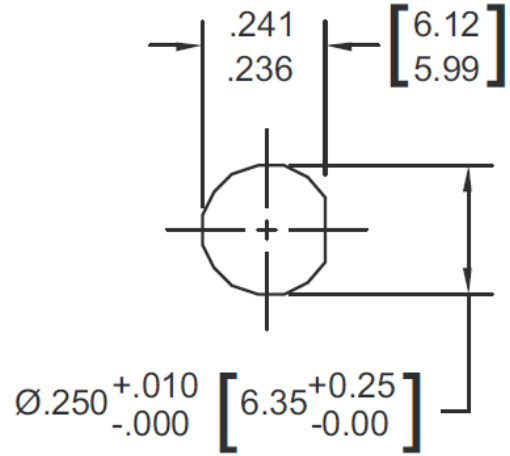
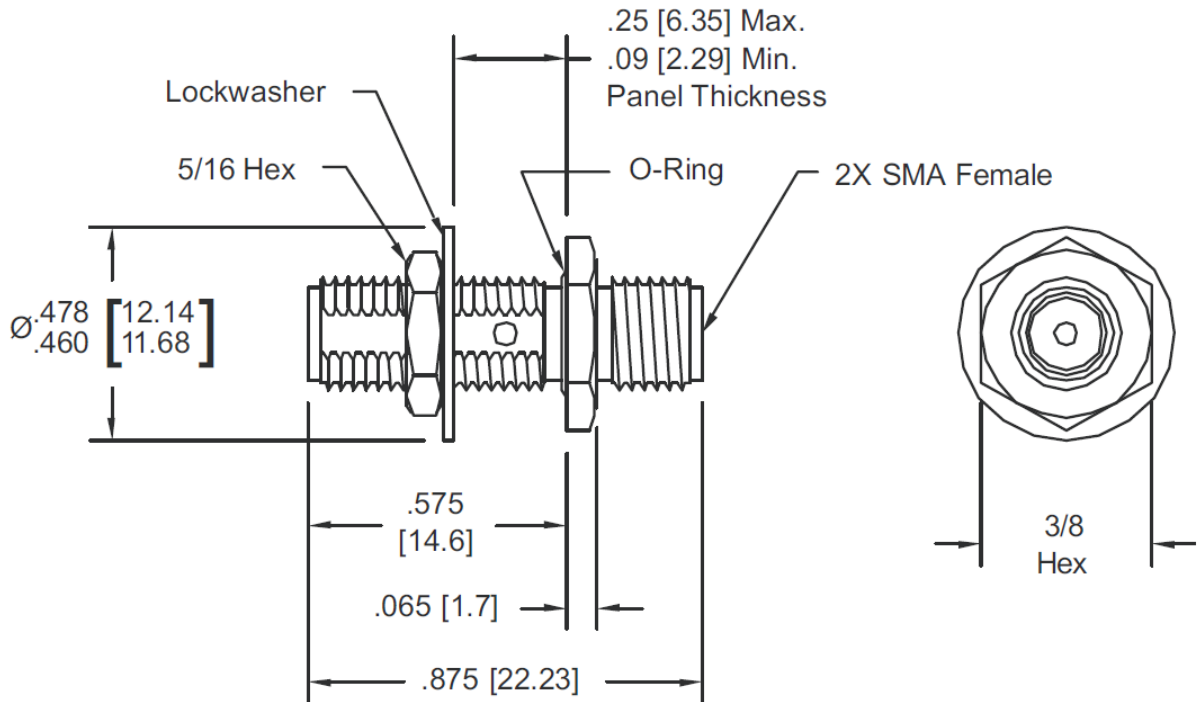

Technical Specifications
RoHS
 Compliant

Parameter	Value
<i>Electrical</i>	
Frequency Range	DC – 3 GHz
VSWR	1.10:1 max.
Impedance	50 Ohms
Operation Temp. Range	-55°C to +125°C
<i>Mechanical</i>	
Connectors Mates with MIL-STD-348	Passivated Stainless Steel
Conductors	Gold Plated Beryllium Copper
Nut & Washer	Passivated Stainless Steel
O-Ring	Silicone Rubber

Recommended Mounting Hole
Model Number 5211-137

**Dimensions in brackets are expressed in millimeters and are for reference only.

sales@am.spectrumcontrol.com

Approved for Release: January 2025/Brown

Spectrum Control reserves the right to make changes to datasheets at any time without notice.