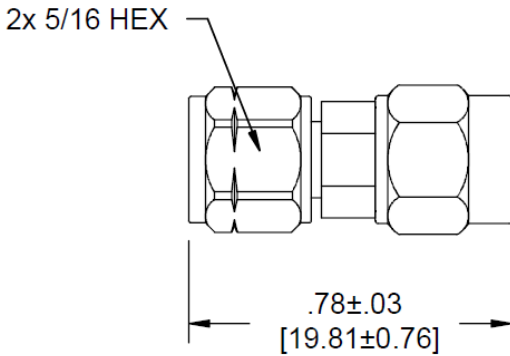
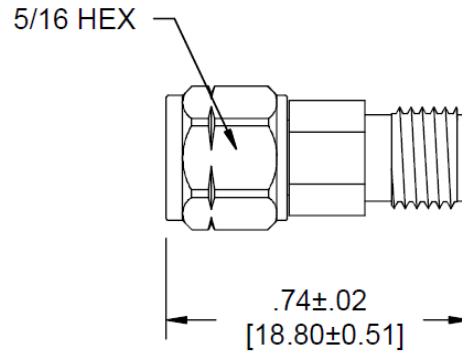
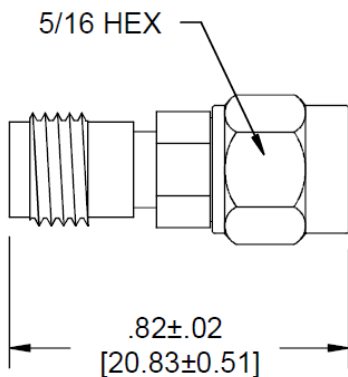
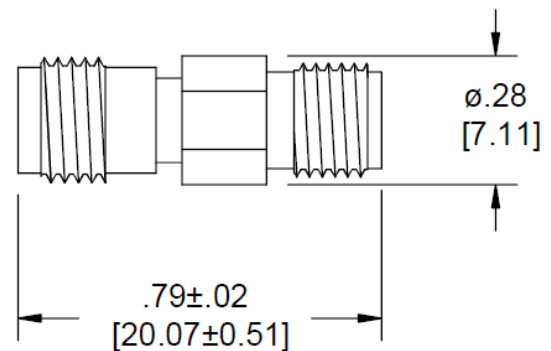

Technical Specifications

Parameter	Value
<i>Electrical</i>	
Frequency Range	DC – 26.5 GHz
VSWR	1.20:1 max.
Impedance	50 Ohms
Operation Temp. Range	-65°C to +125°C

Parameter	Value
<i>Mechanical</i>	
2.4mm Connectors Mates with 1.85mm & V* Connectors	Passivated Stainless Steel
SMA Connectors Mates with MIL-STD-348	Passivated Stainless Steel
Conductors	Gold Plated Beryllium Copper

*V is a trademark of Anritsu Corp.

Model Number 5080
 2.4mm MALE / SMA MALE

Model Number 5082
 2.4mm MALE / SMA FEMALE

Model Number 5081
 2.4mm FEMALE / SMA MALE

Model Number 5083
 2.4mm FEMALE / SMA FEMALE

**Dimensions in brackets are expressed in millimeters and are for reference only.

sales@am.spectrumcontrol.com

Approved for Release: November 2024/Brown

Spectrum Control reserves the right to make changes to datasheets at any time without notice.