

Model 1593

Broadband Resistive Power Splitter (Matching), Subminiature, 3.5mm Connectors

DC to 26.5 GHz
1 Watt

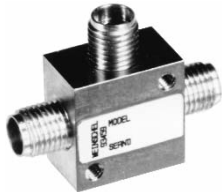

Features

These resistive power splitters are intended for RF and wireless applications in which one of the two outputs is included in a leveling loop or is used as a reference in a ratio system, for the purpose of providing an output signal whose source impedance is essentially matched to 50Ω. Some examples are:

- /// A dual channel insertion loss measuring system (ratio).
- /// A parallel IF substitution insertion loss measuring system (ratio or ALC loop).
- /// A precision power source (ratio or ALC loop).

Specifications

NOMINAL IMPEDANCE: 50 Ω
FREQUENCY RANGE: dc to 26.5 GHz
INSERTION LOSS: 6 dB nominal, 8.5 dB maximum
 (Between input and either output)
MAXIMUM INPUT POWER: 1.0 watts CW (Input Connector only)

AMPLITUDE & PHASE TRACKING (Maximum):

Frequency (GHz)	Tracking	
	Amplitude	Phase
dc - 26.5	<0.25 dB	<4°

MAXIMUM INPUT SWR:

Frequency (GHz)	Maximum SWR
dc - 26.5	1.25

EQUIVALENT OUTPUT SWR (Port 2 & 3):

Frequency (GHz)	Maximum SWR
dc - 18	1.25
18 - 26.5	1.35

*When used in a leveling or ration system.

TEMPERATURE RANGE:

Operating: -55°C to +85°C
 Storage: -55°C to +125°C

TEST DATA: Insertion Loss, SWR, and Tracking measurements performed across the frequency band. Test data available at additional cost.

CONNECTORS: Female 3.5mm connectors all ports --mate nondestructively with SMA, 2.92mm and other 3.5mm connectors.

WEIGHT: 25 g (0.9 oz) maximum

PHYSICAL DIMENSIONS:

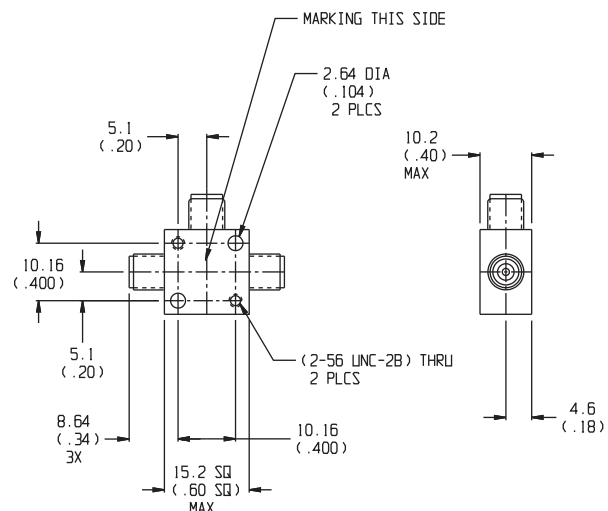

NOTE: All dimensions are given in mm (inches) and are maximum, unless otherwise specified.