

Model 150

Model 151

Model 152

Relay Switched Programmable Attenuators

dc to 18.0 GHz

dc to 4.0 GHz

dc to 26.5 GHz

 **RoHS**



Description

The Model 150, 151 and 152 Programmable Step Attenuators represent the widest variety of programmable attenuators available. This attenuator design is the result of an extensive development program and offers long reliable operation with exceptional accuracy and repeatability. These attenuators can provide programmable adjustments of RF signal levels in precise steps of 1 dB, 5 dB, 10 dB, or with custom steps available. Each attenuator consists of a cascaded assembly of switched attenuator cells (Figure 1). The attenuator elements located in the attenuator cell are created by a thin-film process which provides exceptional long-term stability, low power and temperature coefficients. This series uses a reed switching structure that provides rapid switching together with low insertion loss.

Other features include:

- /// Broadband Frequency Coverage
- /// High Accuracy and Repeatability
- /// Long Life, 5 Million Cycles Per Cell
- /// 3, 4, and 5 Cell Configurations

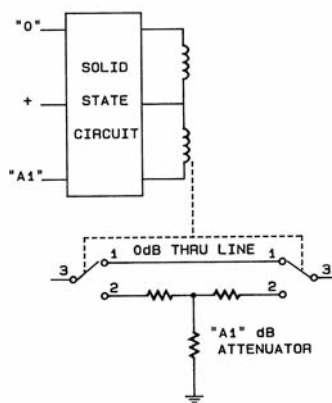

Figure 1. Cell Schematic

PROGRAMMABILITY: In each programmable step Attenuator, solenoids are used to switch the internal resistor card of each cell into and out of the circuit. Once the cell is switched, the solenoid is magnetically latched into position and is able to withstand extreme shock and vibration. Internal circuitry is included to interrupt the coil current after switching is complete. This reduces power dissipation even if power is continuously applied. The switching time for each cell is rated at 20 msec maximum which includes the contact settling time.

BROADBAND ACCURACY & LOW SWR: The use of Spectrum Control / Weinschel's proprietary thin-film resistor process provides these programmable step attenuators with a high degree of accuracy and the lowest possible SWR uncertainty (refer to specifications for actual values). This thin film process permits the construction of circuits which are truly distributed and without stray reactances, even at the higher microwave frequencies.

RELIABILITY: Each programmable step attenuator is composed of 3 to 5 (4 in most models) cells. As with all mechanical designs, usable life becomes a primary concern to the user. With this in mind Spectrum Control / Weinschel backs all these attenuators with a rated switch life of 5 million operations per cell. Standardized testing is also performed on each programmable step attenuator over its operating frequency range by a computer controlled Spectrum Control / Weinschel Attenuation Measurement System which is traceable to NIST standards.

ENVIRONMENTAL: These Model 150 Programmable Step Attenuators have undergone an extensive environmental qualification program and have been subjected to temperature, shock, vibration, and humidity conditions per MIL-STD-202F. These programmable step attenuators operate within these specifications at an ambient temperature of -20° to +75°C. Operating beyond these limits will adversely affect the accuracy and could damage the internal circuitry.

150 Series Cell Configurations...

ATTN Value	Cells No.	Cell 1		Cell 2		Cell 3		Cell 4		Cell 5		Power +Vdc
		Bypass	ATTN Element	Bypass	ATTN Element	Bypass	ATTN Element	Bypass	ATTN Element	Bypass	ATTN Element	
11 dB	4	0 dB	1 dB	0 dB	4 dB	0 dB	2 dB	0 dB	4 dB	---	---	
15 dB	4	0 dB	1 dB	0 dB	8 dB	0 dB	2 dB	0 dB	4 dB	---	---	
31 dB	5	0 dB	1 dB	0 dB	8 dB	0 dB	2 dB	0 dB	16 dB	0 dB	4 dB	
62 dB	5	0 dB	2 dB	0 dB	32 dB	0 dB	16 dB	0 dB	4 dB	0 dB	8 dB	
55 dB	4	0 dB	5 dB	0 dB	10 dB	0 dB	20 dB	0 dB	20 dB	---	---	
70 dB	4	0 dB	10 dB	0 dB	20 dB	0 dB	20 dB	0 dB	20 dB	---	---	
	3	0 dB	10 dB	0 dB	40 dB	0 dB	20 dB	---	---	---	---	
75 dB	4	0 dB	5 dB	0 dB	40 dB	0 dB	20 dB	0 dB	10 dB	---	---	
90 dB	4	0 dB	10 dB	0 dB	30 dB	0 dB	20 dB	0 dB	30 dB	---	---	
110 dB	4	0 dB	10 dB	0 dB	40 dB	0 dB	20 dB	0 dB	40 dB	---	---	
Round Conn.	PIN #	5	6	9	10	7	8	11	12	3	4	1
3 & 4 Cell	Wire Color	Violet	Yellow	Orange	Blue	Black	Green	Brown	White	---	---	Red
5 Cell	Wire Color	Black	White	Green	Orange	Blue	WHT/BLK	RED/BLK	GRN/BLK	ORN/BLK	BLU/BLK	Red
Ribbon Cable Conn.	PIN#	13	2	3	9	11	5	4	10	8	7	6
	Wire Color	Orange	Yellow	Blue	Brown	Purple	Black	Gray	White	Orange	yellow	Red

Table provides standard attenuation ranges, increments, and cell configurations for all Spectrum Control / Weinschel Programmable Step Attenuators (Models 150, 151, 152, & 152A)

Specifications

NOMINAL IMPEDANCE: 50 Ω

FREQUENCY RANGE: Model 151: dc to 4 GHz
 Model 150: dc to 18 GHz
 Model 152: dc to 26.5 GHz

OPERATIONAL VOLTAGE: + 24V Nominal (+20V minimum to +30V maximum) or +5V Nominal (+4V minimum* to +7V maximum)

*Minimum operating voltage derated to +4.25 V @ 55°C and further derated to +4.5 V @ 75°C

POWER RATING: 1 watt average, 100 watts peak (5 μsec pulse width; 0.5% duty cycle)

TEMPERATURE: -20° to +75°C operating

TEMPERATURE COEFFICIENT: < 0.0001 dB/dB/°C

POWER SENSITIVITY: < 0.001 dB/dB/ Watt

RATED SWITCH LIFE: 5 million cycles per cell

RF INPUT CONNECTORS: Rugged female 3.5 mm connectors which mate nondestructively with SMA male connectors per MIL-STD-39012.

CONTROL CONNECTOR: 12 pin Viking TNP12-101 connector with 5' cable or 14 conductor 16" ribbon cable with connector (shown below):

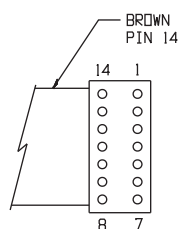

Ribbon Cable Models

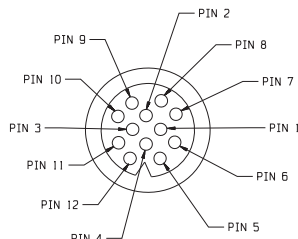

Round (Viking) Cable Models

SWITCHING TIME: 20 msec (includes settling time)

CYCLING RATE: 4 Hz max per relay

CONTROL PULSE WIDTH: 20 msec (minimum)

SWITCHING CURRENT: 125 mA @ +24V per cell
 300 mA @ +5V per cell

REPEATABILITY: ±0.1 dB typical per cell

VIBRATION: MIL-STD-202F, Method 204D Cond B

ALTITUDE: MIL-STD-202F, Method 105C Cond B, 50,000 Ft.

SHOCK: MIL-STD -202F, Method 213B Cond B, except 10G, 6 msec

HUMIDITY: MIL-STD-202F, Method 103B, Cond. B (96 Hrs. @ 95%, RH)

EMC: Radiated interference is within the requirements of MIL-STD-461 method RE02, VDE 0871 and CISPR Publication II.

WEIGHT: 5 Cell 350 g (12 oz)
 4 Cell 290 g (9.0 oz)
 3 Cell 230 g (8.0 oz)

VOLTAGE/CONNECTOR OPTIONS:

VOLTAGE	MODEL(S)
+ 24 V with Viking Connector	150-XX, 151-XX, 152-XX, 152A-XX
+ 24 V with Ribbon Cable	150-XX-1, 151-XX-1, 152-XX-1, 152A-XX-1
+ 5 V with Viking Connector	150-XX-2, 151-XX-2, 152-XX-2, 152A-XX-2
+ 5 V with Ribbon Cable	150-XX-3, 151-XX-3, 152-XX-3, 152A-XX-3

MAXIMUM SWR (50 Ω Characteristic Impedance):

APPLICABLE MODELS	Frequency (GHz)		
	dc-4	4-18	18-26.5
151-11, 151-15, 151-31, 150-62, 151-75, 151-110	1.50	---	---
150-11, 150-15, 150-31, 151-62, 150-75, 150-110	1.50	1.90	---
151-70 (3 cell)	1.35	---	---
150-70 (3 cell)	1.35	1.70	---
152A-70 (3 cell)	1.40	1.70	1.80
152-55, 152-70, 152-90	1.40	1.60	1.90

MAXIMUM INSERTION LOSS (dB):

APPLICABLE MODELS	Frequency (GHz)		
	dc-4	4-18	18-26.5
151-11, 151-15, 151-75, 151-110	0.90	---	---
150-11, 150-15, 150-75, 150-110	0.90	2.20	---
151-31, 150-62 (5 cell)	1.10	---	---
150-31, 151-62 (5 cell)	1.10	2.60*	---
151-70 (3 cell)	0.70	---	---
150-70 (3 cell)	0.70	1.60	---
152A-70 (3 cell)	0.90	2.00	2.98
152-55, 152-70, 152-90	0.90	2.00	2.98

*4-12.4 is 1.80, 12.4-18 is 2.60

ATTENUATION ACCURACY (±dB with respect to 0 dB reference):

Model 150/151/152-11 & 150/151/152-15:

Frequency Range (GHz)	Attenuation Setting (dB)														
	1	2	3	4	5	6	7	8	9	10	11	12	13	14	15
dc-4	0.2	0.2	0.3	0.3	0.3	0.3	0.4	0.4	0.4	0.4	0.5	0.5	0.5	0.5	0.5
4-12.4	0.3	0.3	0.4	0.4	0.5	0.5	0.6	0.6	0.6	0.6	0.7	0.7	0.7	0.7	0.7
12.4-18	0.5	0.6	0.6	0.6	0.6	0.7	0.7	0.7	0.7	0.8	0.8	0.8	0.8	0.8	0.8
18-26.5	0.5	0.6	0.7	0.8	0.9	0.9	0.9	1.0	1.1	1.1	1.1	1.1	1.1	1.1	1.1

Model 150/151-75:

Frequency Range (GHz)	Attenuation Setting (dB)														
	5	10	15	20	25	30	35	40	45	50	55	60	65	70	75
dc-4	0.2	0.2	0.4	0.4	0.5	0.5	0.7	0.7	0.9	0.9	1.1	1.1	1.2	1.2	1.4
4-12.4	0.3	0.3	0.6	0.6	0.9	0.9	1.2	1.2	1.5	1.5	1.8	1.8	2.1	2.1	2.1
12.4-18	0.4	0.4	0.8	0.8	1.2	1.2	1.6	1.6	2.0	2.0	2.4	2.4	2.8	2.8	2.8

Model 150/151-31:

Frequency Range (GHz)	Attenuation Setting (dB)															
	1	2	3	4	5	6	7	8	9	10	11	12	13	14	15	16
dc-4	0.2	0.2	0.3	0.3	0.3	0.3	0.4	0.4	0.5	0.4	0.5	0.5	0.5	0.5	0.5	0.5
4-12.4	0.4	0.4	0.5	0.4	0.6	0.6	0.7	0.6	0.7	0.6	0.7	0.7	0.7	0.7	0.7	0.7
12.4-18	0.5	0.5	0.6	0.6	0.6	0.6	0.7	0.7	0.8	0.8	0.8	0.8	0.8	0.8	0.8	0.8

Frequency Range (GHz)	Attenuation Setting (dB)														
	17	18	19	20	21	22	23	24	25	26	27	28	29	30	31
dc-4	0.5	0.6	0.6	0.6	0.6	0.6	0.6	0.6	0.7	0.7	0.7	0.7	0.7	0.8	0.8
4-12.4	0.8	0.8	0.9	0.9	0.9	0.9	0.9	0.9	1.1	1.0	1.0	1.0	1.0	1.1	1.1
12.4-18	0.9	0.9	1.0	1.0	1.0	1.0	1.1	1.1	1.2	1.2	1.2	1.2	1.2	1.3	1.3

Model 150/151-62:

Frequency Range (GHz)	Attenuation Setting (dB)															
	2	4	6	8	10	12	14	16	18	20	22	24	26	28	30	32
dc-4	0.3	0.3	0.3	0.4	0.4	0.5	0.5	0.5	0.5	0.5	0.5	0.5	0.5	0.5	0.6	0.6
4-12.4	0.4	0.4	0.4	0.5	0.5	0.6	0.6	0.6	0.7	0.7	0.8	0.8	0.8	0.8	0.8	0.8
12.4-18	0.5	0.5	0.5	0.6	0.6	0.6	0.8	0.8	0.8	0.8	0.8	1.0	1.0	1.0	1.2	1.2

Frequency Range (GHz)	Attenuation Setting (dB)															
	34	36	38	40	42	44	46	48	50	52	54	56	58	60	62	
dc-4	0.6	0.6	0.7	0.7	0.7	0.8	0.8	0.8	0.9	0.9	0.9	1.0	1.0	1.0	1.2	
4-12.4	1.0	1.0	1.1	1.1	1.3	1.4	1.4	1.4	1.5	1.6	1.6	1.6	1.8	1.8	1.8	
12.4-18	1.4	1.4	1.6	1.6	1.8	1.8	2.0	2.0	2.0	2.2	2.2	2.2	2.4	2.4	2.4	

Model 150/151-70, 150/151/152A-70:

Frequency Range (GHz)	Attenuation Setting (dB)										
	10	20	30	40	50	60	70	80	90	100	110
dc-4	0.2	0.3	0.5	0.7	0.9	1.0	1.2	1.4	1.6	1.7	1.9
4-12.4	0.4	0.7	0.9	1.2	1.5	1.8	2.1	2.4	2.7	3.0	3.0
12.4-18	0.4	0.8	1.2	1.6	2.0	2.4	2.8	3.2	3.6	4.0	4.0
18-26.5	0.5	0.9	1.3	2.0	2.2	2.6	3.2	N/A	N/A	N/A	N/A

Model 152-55:

Frequency Range (GHz)	Attenuation Setting (dB)										
	5	10	15	20	25	30	35	40	45	50	55
dc-4	0.2	0.3	0.4	0.4	0.4	0.6	0.6	0.7	0.7	0.8	1.0
4-12.4	0.3	0.4	0.5	0.5	0.5	0.7	0.8	0.9	0.9	1.0	1.3
12.4-18	0.4	0.4	0.5	0.5	0.5	0.8	1.0	1.1	1.1	1.2	1.6
18-26.5	0.5	0.5	0.6	0.6	0.6	0.9	1.2	1.4	1.4	1.5	2.0

Model 152-70 & 152-90:

Frequency Range (GHz)	Attenuation Setting (dB)								
	10	20	30	40	50	60	70	80	90
dc-4	0.3	0.5	0.6	0.7	0.8	1.0	1.1	1.1	1.2
4-12.4	0.4	0.5	0.7	0.9	1.0	1.3	1.5	1.6	1.7
12.4-18	0.5	0.6	0.8	1.1	1.2	1.4	1.7	1.8	2.1
18-26.5	0.5	0.6	0.9	1.4	1.5	1.8	2.3	2.4	2.8

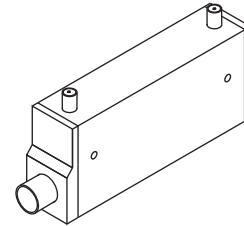

Programmable Attenuators



PHYSICAL DIMENSIONS:

Models 150, 151, & 152:

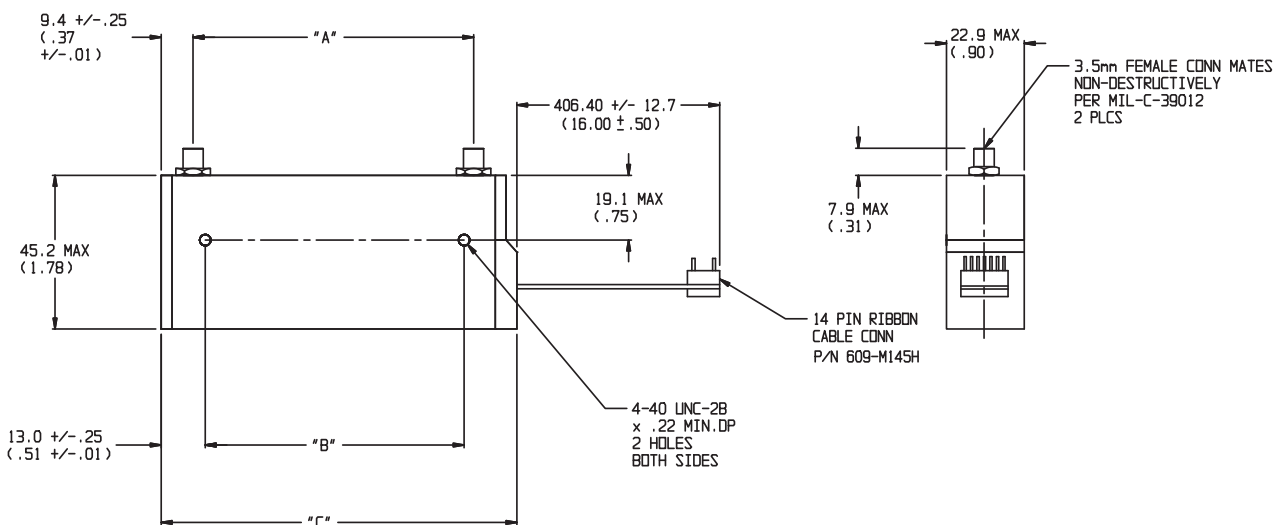
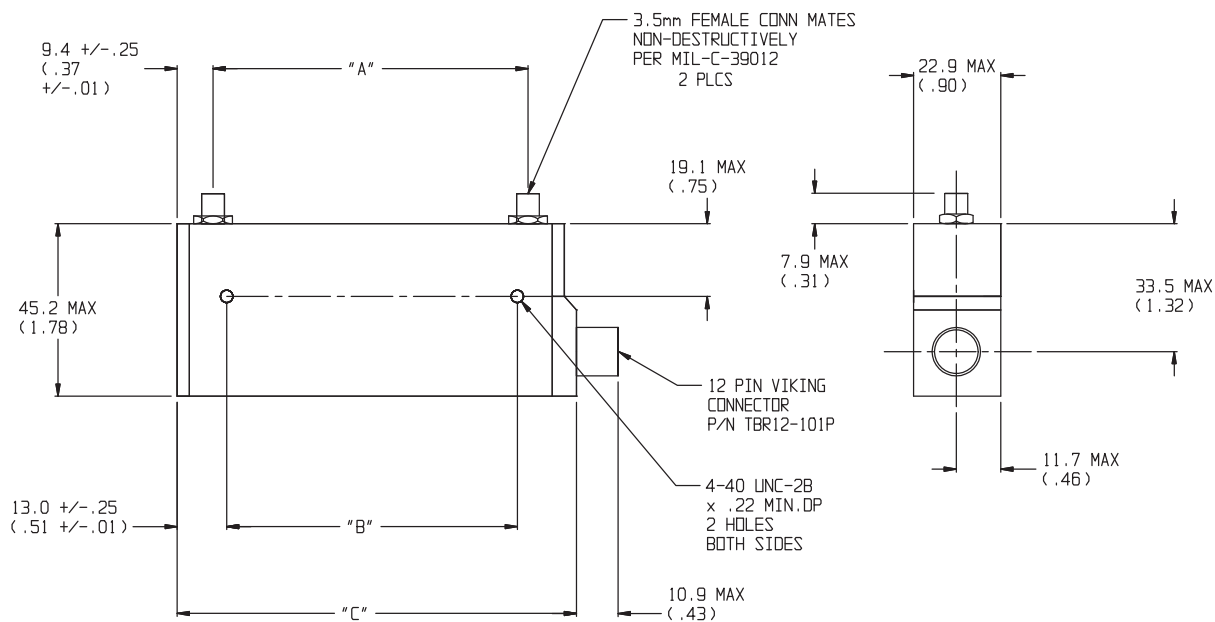

DIM	A	B	C
3 cell	82.3 (3.28)	76.2 (3.0)	105.7 (4.16)
4 cell	110.7 (4.36)	103.7 (4.08)	133.6 (5.25)
5 cell	136.1 (5.36)	129.1 (5.08)	159.5 (6.28)

NOTE:

1. All dimensions are given in mm (inches) and are maximum, unless otherwise specified.
2. Unit available with RoHS compliant materials, specify when ordering.

150 Series Ordering Guide...

Frequency Range/ Voltage/Connector	NO. Cells	Attenuator Range/Step Size								
		11/1 dB	15/1 dB	55/5 dB	31/1 dB	62/2 dB	70/10 dB	75/5 dB	90/10 dB	110/10 dB
dc-4 GHz/+24 V/ Viking Connector	4 3 5	151-11	NA	N/A	151-31	151-62	N/A	151-75	N/A	151-110
dc-18 GHz/+24 V/ Viking Connector	4 3 5	150-11	150-15	N/A	150-31	150-62	150-70	150-75	N/A	150-110
dc-26.5 GHz/+24 V/ Viking Connector	4 3	N/A	N/A	152-55	N/A	N/A	N/A	N/A	152-90	N/A
dc-4 GHz/+24 V/ Ribbon Cable	4 3 5	151-11-1	NA	N/A	151-31-1	151-62-1	N/A	151-75-1	N/A	151-110-1
dc-18 GHz/+24 V/ Ribbon Cable	4 3 5	150-11-1	150-15-1	N/A	150-31-1	150-62-1	150-70-1	N/A	N/A	150-110-1
dc-26.5 GHz/+24 V/ Ribbon Cable	4 3	N/A	N/A	152-55-1	N/A	N/A	N/A	N/A	152-90-1	N/A
dc-4 GHz/+5 V/ Viking Connector	4 3 5	151-11-2	151-15-2	N/A	151-31-2	151-62-2	N/A	151-75-2	N/A	151-110-2
dc-18 GHz/+5 V/ Viking Connector	4 3 5	150-11-2	150-15-2	N/A	150-31-2	150-62-2	150-70-2	150-75-2	N/A	N/A
dc-26.5 GHz/+5 V/ Viking Connector	4 3	N/A	N/A	152-55-2	N/A	N/A	N/A	N/A	152-90-2	N/A
dc-4 GHz/+5 V/ Ribbon Cable	4 3 5	151-11-3	N/A	N/A	151-31-3	151-62-3	N/A	N/A	N/A	N/A
dc-18 GHz/+5 V/ Ribbon Cable	4 3 5	150-11-3	150-15-3	N/A	150-31-3	150-62-3	150-70-3	150-75-3	N/A	150-110-3
dc-26.5 GHz/+5 V/ Ribbon Cable	4 3	N/A	N/A	152-55-3	N/A		N/A	N/A	152-90-3	N/A

N/A = Not Available

ACCESSORIES

OPTIONAL TEST DATA: Test Data is available at an additional cost for all programmable step attenuators models. Sweep Data across the programmable attenuator's frequency band starting at 0.05 to 18.0/26.5 GHz for all primary cells with markers at 0.05, 4.0, 8.0, 12.4, 18.0 and 26.5 GHz. VSWR and Attenuation provided.

MODELS WITH BUILT-IN TTL/CMOS INTERFACE\

DRIVER CIRCUIT: Spectrum Control / Weinschel offers versions of the 150 series with built-in TTL/CMOS interfaces. This generation of intelligent attenuators will greatly simplify as well as provide an economical solution to 150 series driver problems. Refer to Model 150T, 151T, and 152T data sheet for more information.