

TITLE		API TECHNOLOGIES	
OUTLINE DRAWING,		SIZE	
QBH-2818		A	
SCALE: 1/1		CAGE CODE	
REV B		55027	
SHEET 2 OF 2		DWG NO.	
		080-22675	

NOTES: UNLESS OTHERWISE SPECIFIED,

1. INTERPRET DWG IAW MIL-STD-100.
2. ABBREVIATIONS IAW MIL-STD-12.
3. INTERPRET THIRD ANGLE PROJECTION  
 (ISO-A).
4. DIMENSIONS ARE IN INCHES.
5. DO NOT SCALE THIS DRAWING.

6. INTERPRET DIMENSIONING SYMBOLS IAW ANSI Y14.5M.

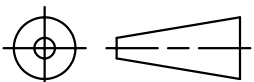

7. MATERIAL: HEAT SINK - ALUMINUM ALLOY 360  
 COVER - 15% GLASS REINFORCED PBT RESIN  
 COLOR - WHITE  
 LEADS - PHOSPHOR BRONZE



8. FINISH: HEAT SINK - 25-35 μIN PURE SULFAMATE NICKEL,  
 OVER COPPER STRIKE, OVER DOUBLE ZINCATE

LEADS - 30-60 μIN GOLD OVER NICKEL

