

DESCRIPTION

- 500 MHz SAW bandpass filter with 1 MHz bandwidth.
- 7 x 9 mm 11-pad LCC package.
- RoHS compliant.

TYPICAL PERFORMANCE

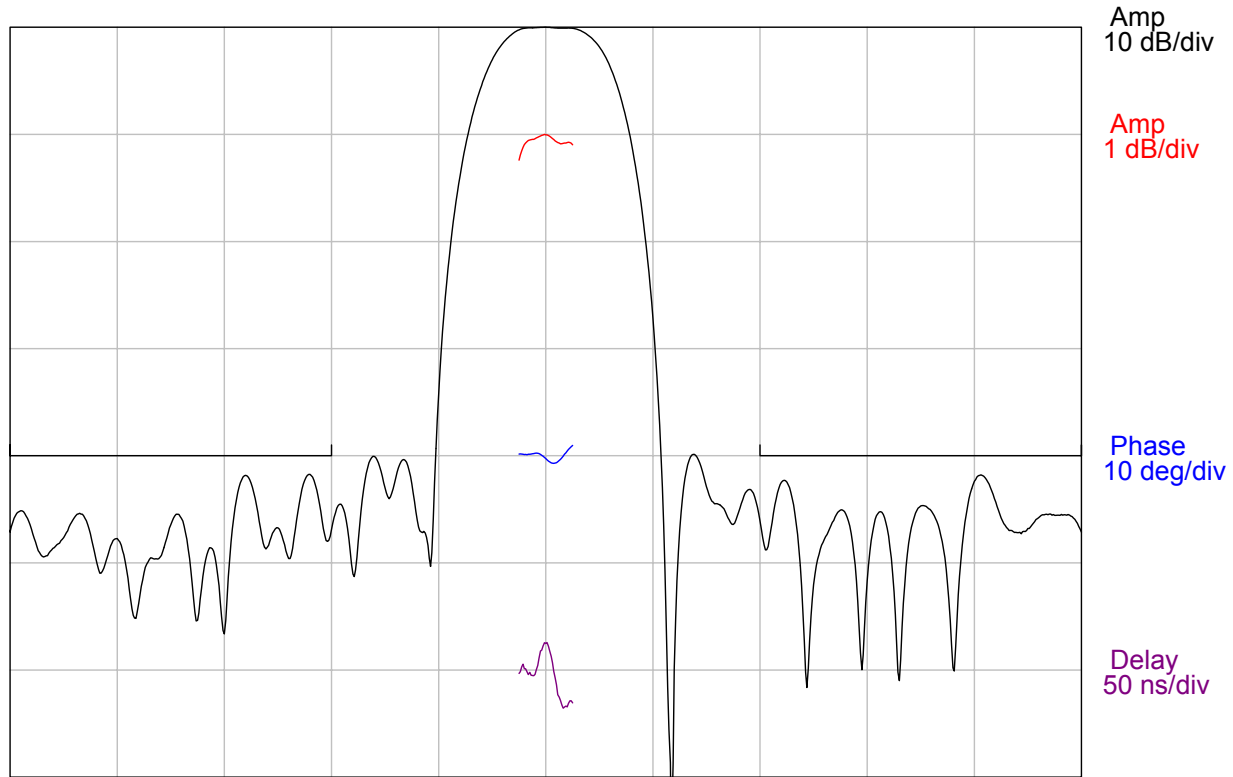

Center = 500 MHz, 2 MHz/div (25 kHz incr)

S11 (490-510 MHz)

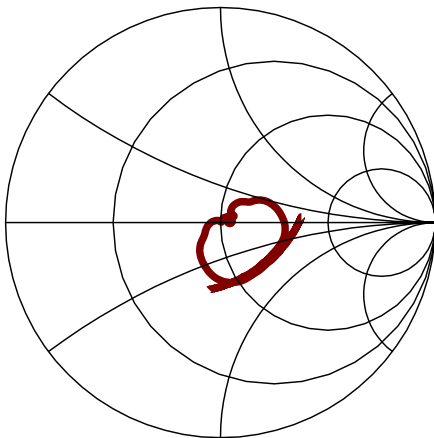

S22 (490-510 MHz)

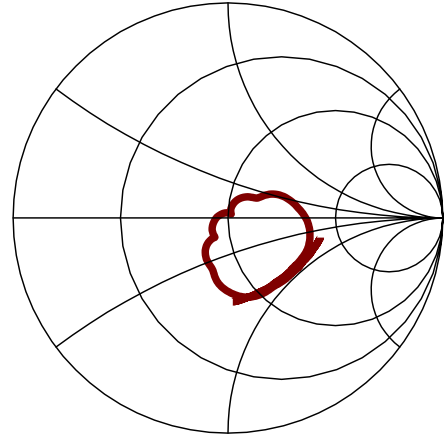

SPECIFICATION

Parameter	Min	Typ	Max	Units
3 dB Center Frequency, F_c	-	500	-	MHz
Minimum Insertion Loss	-	11	14	dB
Lower 1 dB Frequency ¹	-	499.29	499.5	MHz
Upper 1 dB Frequency ¹	500.5	500.85	-	MHz
1 dB Bandwidth ¹	1	1.56	-	MHz
3 dB Bandwidth ¹	-	2.1	-	MHz
40 dB Bandwidth ¹	-	5	8	MHz
In-band Amplitude Variation	-	0.4	1	dB p-p
In-band Group Delay Ripple	-	35	100	ns p-p
Device Delay	-	0.9	-	us
Relative Attenuation:				
10 to 496 MHz ¹	40	42	-	dB
504 to 700 MHz ¹	40	42	-	dB
700 to 1000 MHz ¹	38	40	-	dB
Temperature Coefficient of Frequency (T_c) ²	-0.032			ppm/°C ²
Source/Load Impedance	50			ohms
Ambient Temperature (T_{ref})	25			°C

- Notes:
1. All dB levels are referenced to the insertion loss.
 2. Typical shift of frequency response with temperature is: $\Delta f = (T - T_{ref}) * T_c * F_c$.

MAXIMUM RATINGS

Parameter	Min	Max	Units
Storage Temperature Range	-45	85	°C
Operating Temperature Range (T)	-20	70	°C
Input Power Level	-	10	dBm

MATCHING CIRCUIT

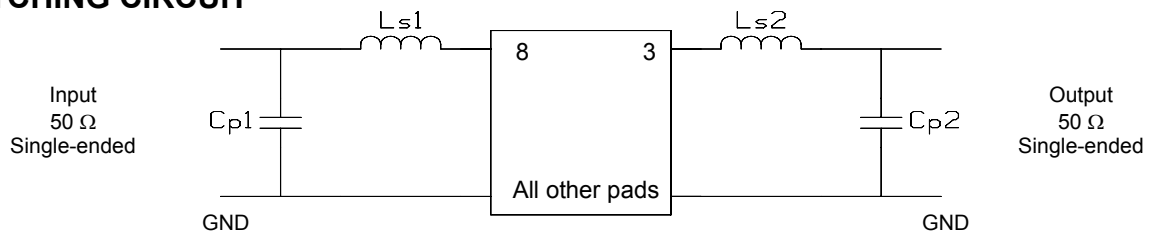

$$L_{s1} = 8.2 \text{ nH}, C_{p1} = 15 \text{ pF}, L_{s2} = 10 \text{ nH}, C_{p2} = 14 \text{ pF}$$

Notes:

- Recommend 2% tolerance matching components. Typical inductor Q=40.
- Matching values are for reference only. Actual values are dependent upon board layout.

PACKAGE OUTLINE

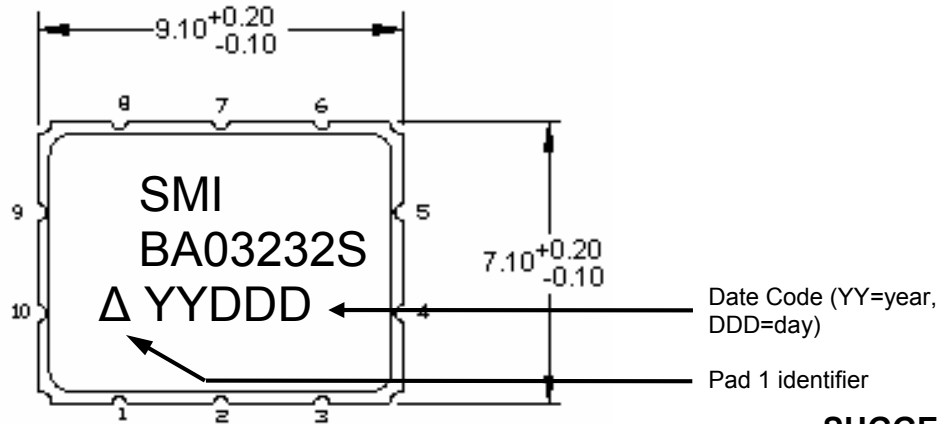

SUGGESTED FOOTPRINT

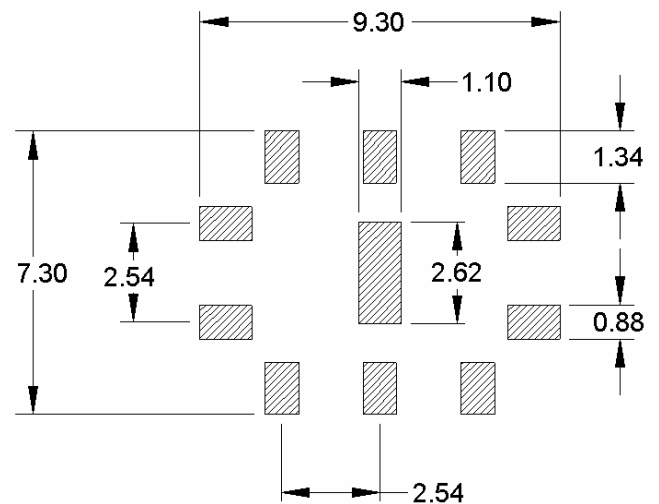

Tolerances are typically ± 0.15 mm except where indicated.

Pad Configuration:

Input: 8
Output: 3
Ground: All other pads

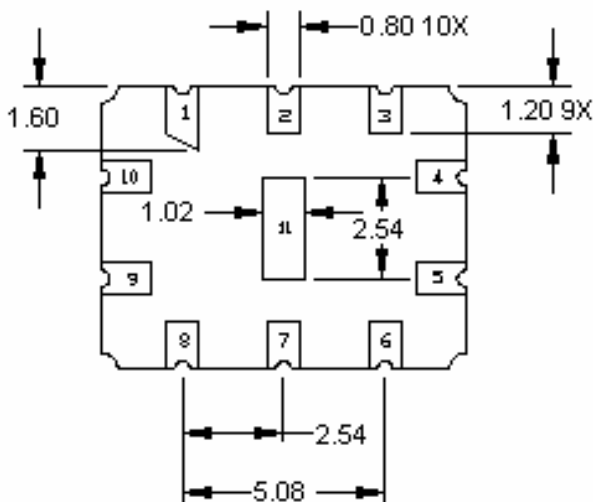

Package Material:
Body: Al_2O_3 ceramic
Lid: Kovar, Ni plated
Terminations: Au plating 1 μ m min, over a 1.3-8.9 μ m Ni plating

ISO 9001
Registered

All specifications are believed to be accurate and reliable. However, Spectrum Microwave reserves the right to make changes without notice.
© 2010 All rights reserved.